

- NOTES:
1. STAINLESS STEEL WOVEN MESH ELEMENTS ARE BUBBLE POINT TESTED PER NFC DEN02-12
 2. PARTS ARE CLEANED TO ASSEMBLY PER NFC OPMF-500
 3. ASSEMBLY PER NFC PSM04-05
 4. BOM CONTROLLED PER DMF01-01
 5. SEE PAGE 2 FOR BOM
 6. SINTERED MEDIA DATA REFERENCED TO MOTT LITERATURE; PARTICLE EFFICIENCY 99.9% OR HIGHER
 7. OUTER DIAMETER DIMENSIONS [REFERENCE ONLY]. SEE PIECE PART DRAWINGS FOR TOLERANCING

REVISIONS			
DRAWING REV.	DESCRIPTION	DATE	APPROVED
L	ECO 1657: UPDATED 17-4 HEAT TREAT FROM H900 TO H1150	5/8/18	KH
M	ECO 1684: UPDATED FILTRATION RATINGS	6/26/2018	AO
N	ECO 2153: UPDATED WORKING MATERIAL CODE 3 TO INCLUDE MONEL	6/6/2019	LW
O	ECO 2347: MEDIA GRADE 02 ADDED	9/27/19	JB

TABLE 1-WORKING MATERIAL		
CODE 1	WORKING PRESSURE	MATERIAL
3	3000 PSI	6061-T651 ALUMINUM PER AMS QQ-A-200/8 ANODIZED PER MIL-A-8625 TYPE II CLASS 2 CHEM FILM RACK MARKS PER MIL-DTL-5541
		303 S.S. PER AMS QQ-S-763
		316/316L S.S. PER AMS QQ-S-763
		BRASS C3600
		MONEL 405 PER ASTM B164
4	6000PSI	17-4 PH STAINLESS STEEL CONDITION H1150 PER ASTM A 564/564M
		316/316L S.S. PER AMS QQ-S-763
		MONEL 405 PER ASTM B164

TABLE 3 - HOUSING MATERIAL		
CODE 3	HOUSING MATERIAL	
A	6061-T651 ALUMINUM PER AMS QQ-A-200/8 ANODIZED PER MIL-A-8625 TYPE II CLASS 2 CHEM FILM RACK MARKS PER MIL-DTL-5541	
G	For 3000 PSI rating: 303 S.S. PER AMS QQ-S-763 FOR 6000 PSI RATING: 17-4 PH STAINLESS STEEL CONDITION H1150 PER ASTM A 564/564M	
T	316/316L S.S. PER AMS QQ-S-763	
B	BRASS C3600	
M	MONEL 405 PER ASTM B164	

TABLE 4 - ELEMENT						
ELEMENT MATERIAL		MICRON RATING			COLLAPSE PRESSURE	
CODE 4a	MATERIAL	CODE 4b	NOMINAL	ABSOLUTE	CODE 4c	COLLAPSE PRESSURE
F	GLASS FIBER	B1	--	1	C	3250 [PSID]
		B3	--	3		
		B5	--	5		
		B10	--	10		
		B25	--	25		
G	PLEATED WOVEN WIRE MESH 316L STAINLESS STEEL MATERIAL PER AMS AMS QQ-S-763	2X	2	10	V	4500 [PSID]
		02	2	12		
		05	5	18		
		10	10	25		
		20	20	40		
		40	40	75		
		75	75	100		
100	100	200				
200	200	300				
R	RANDOM METAL FIBER 316L STAINLESS STEEL METAL PER ASTM A-555	1	--	1	E	4500 [PSID]
		3	--	3		
		5	--	5		
		10	--	10		
		20	--	20		
100	--	100				
B	SINTERED TIN/BRONZE	10	--	10	X	1500 [PSID]
W	NICKEL 200/201 WIRE MESH	10	10	25	V	4500 [PSID]
		75	75	150		
		100	100	200		
ELEMENT MATERIAL		MICRON RATING			COLLAPSE PRESSURE	
CODE 4a	MATERIAL	CODE 4b	GAS ABS	LIQUID ABS	CODE 4c	COLLAPSE PRESSURE
P	POROUS SINTERED 316L STAINLESS STEEL	0.2	0.2	1.4	F	3000 [PSID]
		0.5	0.3	2.2		
		1	0.7	3.3		
		2	2	9		
		5	5	13		
		10	13	20		
20	20	35				
N	NICKEL 200/201 SINTERED	SEE 316 SINTERED			K	3000 [PSID]

TABLE 2 - END FITTING SELECTION CHART											
CASE	PLUG	TUBE SIZE - 1/4" DASH SIZE - '4' PIPE SIZE - N/A		TUBE SIZE - 3/8" DASH SIZE - '6' PIPE SIZE - 1/8"		TUBE SIZE - 1/2" DASH SIZE - '8' PIPE SIZE - 1/4"		TUBE SIZE - 3/4" DASH SIZE - '12' PIPE SIZE - 1/2"		TUBE SIZE - 1" DASH SIZE - 16 PIPE SIZE - 3/4"	
END CONNECTIONS		OUTER DIAMETER - 1.250"		OUTER DIAMETER - 1.750"		OUTER DIAMETER - 1.750"		OUTER DIAMETER - 2.250"		OUTER DIAMETER - 2.500"	
INLET	OUTLET	CODE 2a	BODY LENGTH	CODE 2a	BODY LENGTH	CODE 2a	BODY LENGTH	CODE 2a	BODY LENGTH	CODE 2a	BODY LENGTH
FNPT	FNPT			22	4.750 ± .020	23	6.000 ± .015	25	7.750 ± .020	26	8.75 ± .030
FNPT	F O-RING THD.	N/A		92	4.750 ± .035	93	6.000 ± .020	95	7.750 ± .020	96	8.750 ± .015
FNPT	M O-RING THD.	N/A		52	4.625 ± .035	53	5.875 ± .030	55	7.562 ± .030	56	8.625 ± .030
FNPT	M 37° FLARE*	N/A		152	4.625 ± .035	153	5.875 ± .030	155	7.562 ± .030	156	8.625 ± .030
F O-RING THD.	FNPT	N/A		162	4.750 ± .015	163	6.000 ± .015	165	7.750 ± .020	166	8.750 ± .035
F O-RING THD.	F O-RING THD.	11	4.810 ± .030	12	4.750 ± .030	13	6.000 ± .020	15	7.750 ± .020	16	8.750 ± .020
F O-RING THD.	M O-RING THD.	61	4.560 ± .030	62	4.625 ± .030	63	5.875 ± .030	65	7.562 ± .030	66	8.625 ± .035
F O-RING THD.	M 37° FLARE*	101	4.560 ± .030	102	4.625 ± .030	103	5.875 ± .030	105	7.562 ± .030	106	8.625 ± .035
M O-RING THD.	FNPT	N/A		72	4.380 ± .010	73	5.625 ± .010	75	7.188 ± .015	76	8.375 ± .025
M O-RING THD.	F O-RING THD.	81	4.370 ± .025	82	4.380 ± .025	83	5.625 ± .015	85	7.188 ± .015	86	8.375 ± .010
M O-RING THD.	M O-RING THD.	141	4.120 ± .025	142	4.255 ± .025	143	5.500 ± .025	145	7.000 ± .025	146	8.250 ± .025
M O-RING THD.	M 37° FLARE*	171	4.120 ± .025	172	4.255 ± .025	173	5.500 ± .025	175	7.000 ± .025	176	8.25 ± .025
M 37° FLARE*	FNPT	N/A		112	4.297 ± .010	113	5.625 ± .010	115	7.188 ± .015	116	8.375 ± .025
M 37° FLARE*	F O-RING THD.	121	4.370 ± .025	122	4.297 ± .025	123	5.625 ± .015	125	7.188 ± .015	126	8.375 ± .010
M 37° FLARE*	M O-RING THD.	131	4.120 ± .025	132	4.255 ± .025	133	5.500 ± .025	135	7.000 ± .025	136	8.250 ± .025
M 37° FLARE*	M 37° FLARE*	41	4.120 ± .025	42	4.255 ± .025	43	5.500 ± .025	45	7.000 ± .025	46	8.25 ± .025
ELEMENT SIZE CODE - 2b		411		412		413		415		416	
MINIMUM WALL THICKNESS "t"		.267		.308		.328		.345		.365	

FEMALE O-RING THREADS CUT PER AS - 5202
 MALE O-RING THREADS CUT PER AS - 930
 MALE 37° FLARE CUT PER AS - 4395

TABLE 5 - O-RING MATERIAL	
CODE 5	MATERIAL
M	TEFLON
M1	TEFLON PER AMS 3678C-1-B
E	ETHYL. PROP.
E1	V1238-95
S	SILICONE
L	BUNA-N 70 DUROMETER
K	BUNA 90 DUROMETER
HNBR	HNBR
H	KALREZ-4079
N	VITON
MN	TEFLON COATED VITON
P	POLYPROPYLENE

VITON, TEFLON, AND KALREZ ARE REG. T.M. OF DUPONT CORP.

TABLE 6- ACCESSORIES (OPTIONAL)	
CODE 6	DESCRIPTION
AS-1098	SEAL CUT
LW	LOCKWIRE HOLES

4300/4400 ASSEMBLY KIT: 4 1 2a 3 4a 4b 4c 5 6

EXAMPLE: 4 4 11 T F - B5 C H - LW

REPLACEMENT SEAL KIT: KIT - 43 - 44 -

EXAMPLE: KIT - 43 - 44 11 - H

REPLACEMENT ELEMENT KIT: 2b 4a - 4b 4c 5

EXAMPLE: 411 F B5 C H

UNLESS OTHERWISE SPECIFIED DIMENSIONS ARE IN INCHES

TOLERANCES ON:
 2 PLACE DECIMAL: .XX +/-0.01
 3 PLACE DECIMAL: .XXX +/-0.005
 ANGULAR: +/- 0.5°

 PART TO BE FREE OF BURRS

REMOVE SHARP EDGES (FILLET 0.005" - 0.020") MEASUREMENT NOT REQUIRED SURFACE FINISH 125 Ra UNLESS NOTED, VISUAL INSPECTION ONLY REQUIRED IF PART REVISION IS NOT SPECIFIED, PART REV. MATCHES DRAWING REV. NFC WORKMANSHIP STANDARD DMF01-24 APPLIES

NORMAN FILTERS
 NORMAN FILTER COMPANY
 9850 SOUTH INDUSTRIAL DRIVE - BRIDGEVIEW, IL 60455
 PHONE (708)430-4000 - FAX (708)430-5961

TITLE: 4300/4400 SERIES ASSEMBLY

PART NUMBER: TABULATED

PART REV:

DWG NO. 4300-4400-ASSM

CAGE CODE 59165

SIZE A3

COLLAPSE CODE IS COUPLED TO MATERIAL. EX: "P" MATERIAL MUST BE "F" COLLAPSE CODE

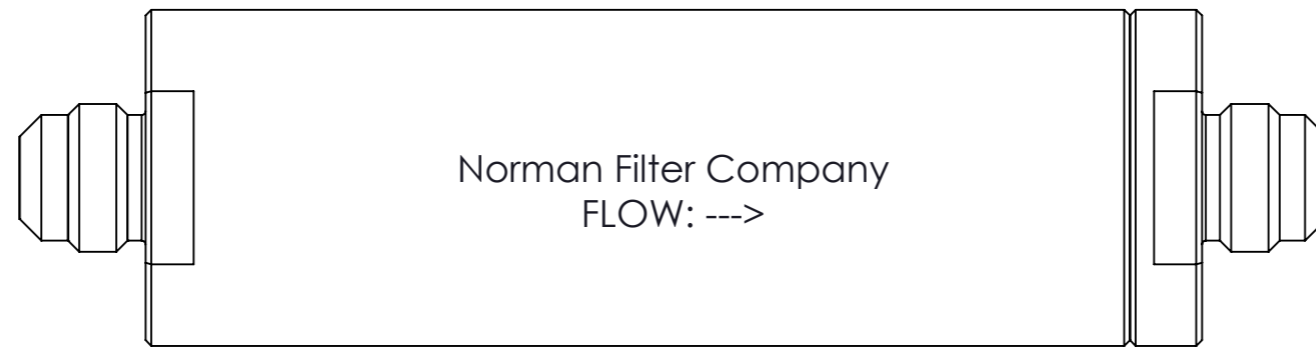

Ø OUTER DIAMETER ± $\frac{.010}{.040}$
SEE TABLE 2

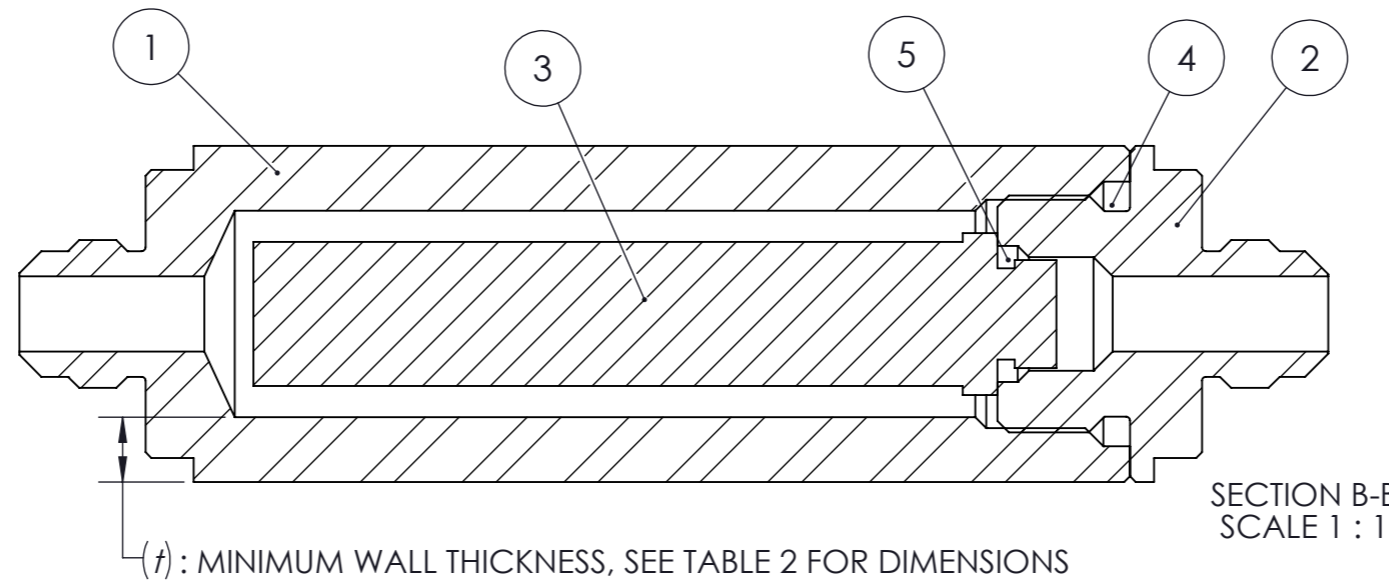
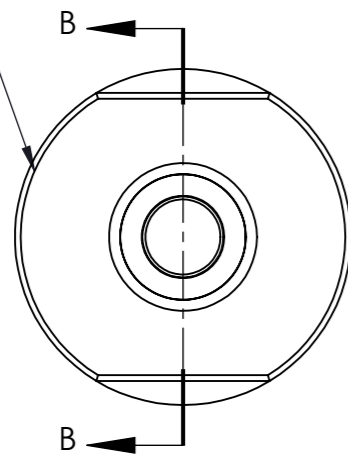

*NOTE: CONTACT NFC SALES FOR PN'S

BILL OF MATERIALS		
ITEM #	DESCRIPTION	QTY.
①	FILTER HOUSING CASE	1
②	FILTER HOUSING PLUG	1
③	ELEMENT	1
④	PLUG O-RING	1
⑤	ELEMENT O-RING	1

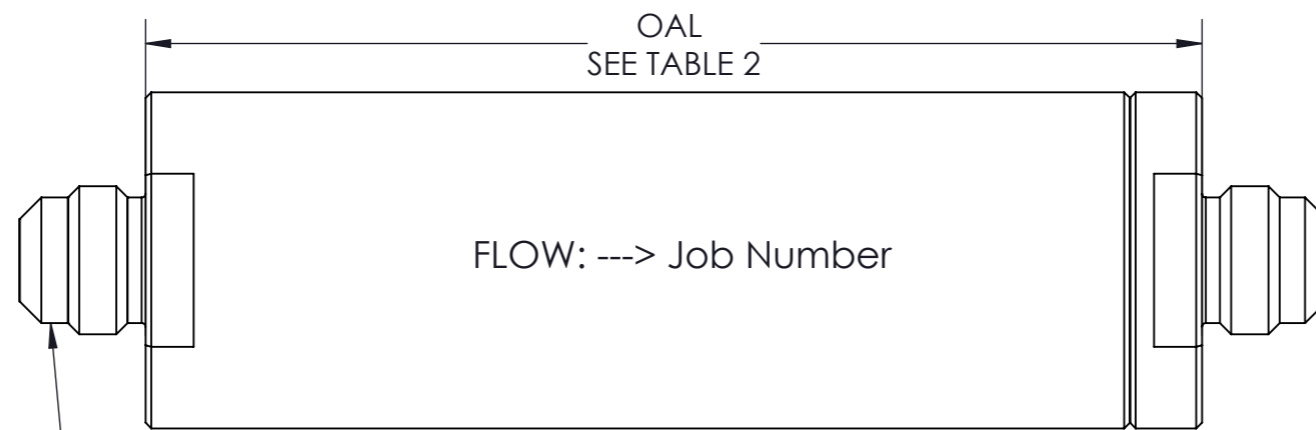

Markings:

Label Information:
P/N
Filtration
Operating Pressure
Element

EXAMPLE FITTINGS ONLY:
SEE TABLE 2 FOR FITTING OPTIONS

UNLESS OTHERWISE SPECIFIED
DIMENSIONS ARE IN INCHES

TOLERANCES ON:
2 PLACE DECIMAL: .XX +/-0.01
3 PLACE DECIMAL: .XXX +/-0.005
ANGULAR: +/- 0.5°

PART TO BE FREE OF BURRS
REMOVE SHARP EDGES (FILLET 0.005" - 0.020") MEASUREMENT NOT REQUIRED
SURFACE FINISH 125 Ra UNLESS NOTED, VISUAL INSPECTION ONLY REQUIRED
IF PART REVISION IS NOT SPECIFIED, PART REV. MATCHES DRAWING REV.
NFC WORKMANSHIP STANDARD DMF01-24 APPLIES



TITLE:
4300/4400 SERIES ASSEMBLY

PART NUMBER:
TABULATED

PART REV:
○

DWG NO.
4300-4400-ASSM

CAGE CODE
59165

SIZE
A3

DO NOT SCALE DRAWING

SCALE:1:2

SHEET 2 OF 3

NOTE:
1. SEE TABLE 2 FOR DIMENSIONS

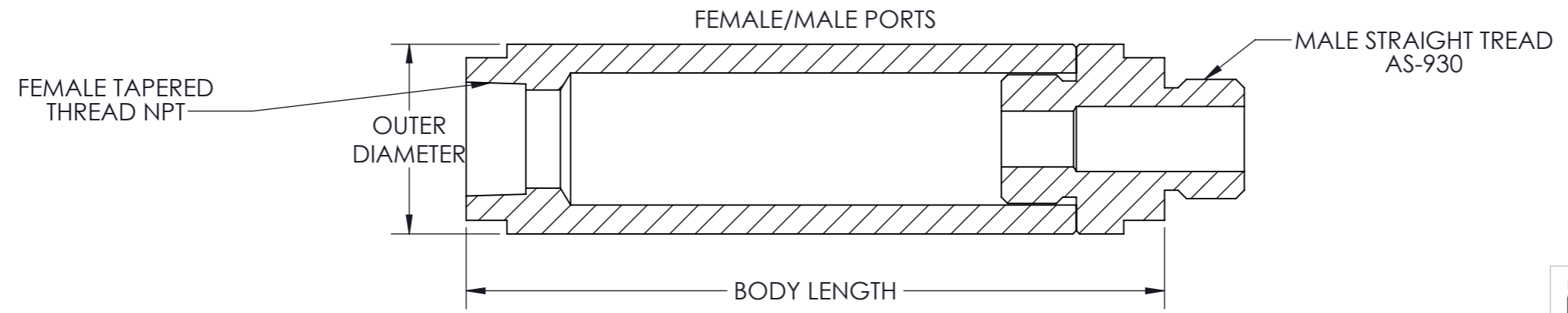
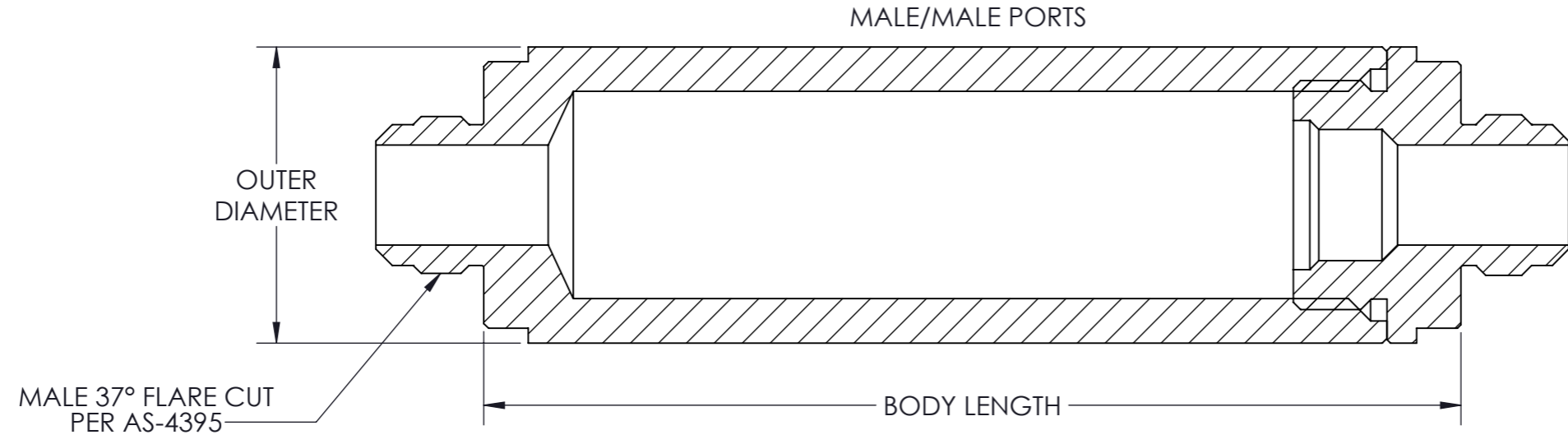
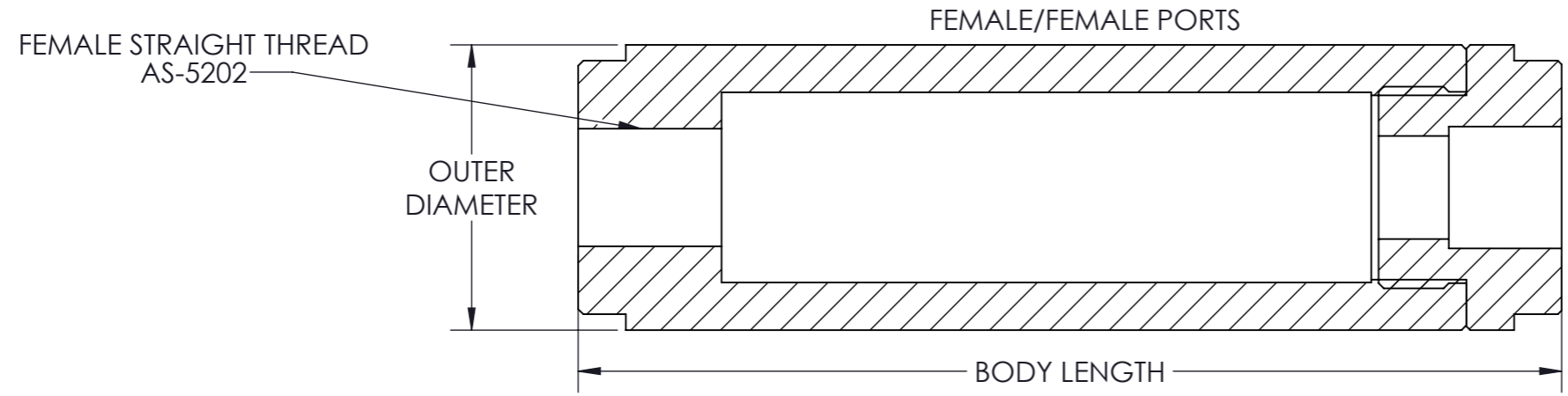

UNLESS OTHERWISE SPECIFIED
DIMENSIONS ARE IN INCHES

TOLERANCES ON:
2 PLACE DECIMAL: .XX +/-0.01
3 PLACE DECIMAL: .XXX +/-0.005
ANGULAR: +/- 0.5°

PART TO BE FREE OF BURRS
REMOVE SHARP EDGES (FILLET 0.005" - 0.020") MEASUREMENT NOT REQUIRED
SURFACE FINISH 125 Ra UNLESS NOTED, VISUAL INSPECTION ONLY REQUIRED
IF PART REVISION IS NOT SPECIFIED, PART REV. MATCHES DRAWING REV.
NFC WORKMANSHIP STANDARD DMF01-24 APPLIES

 NORMAN FILTER COMPANY <small>9850 SOUTH INDUSTRIAL DRIVE - BRIDGEVIEW, IL 60455 PHONE (708)430-4000 - FAX (708)430-5961</small>	
TITLE: 4300/4400 SERIES ASSEMBLY	
PART NUMBER: TABULATED	PART REV: ○
DWG NO. 4300-4400-ASSM	CAGE CODE 59165
SIZE A3	
SCALE:1:2	SHEET 3 OF 3

DO NOT SCALE DRAWING