

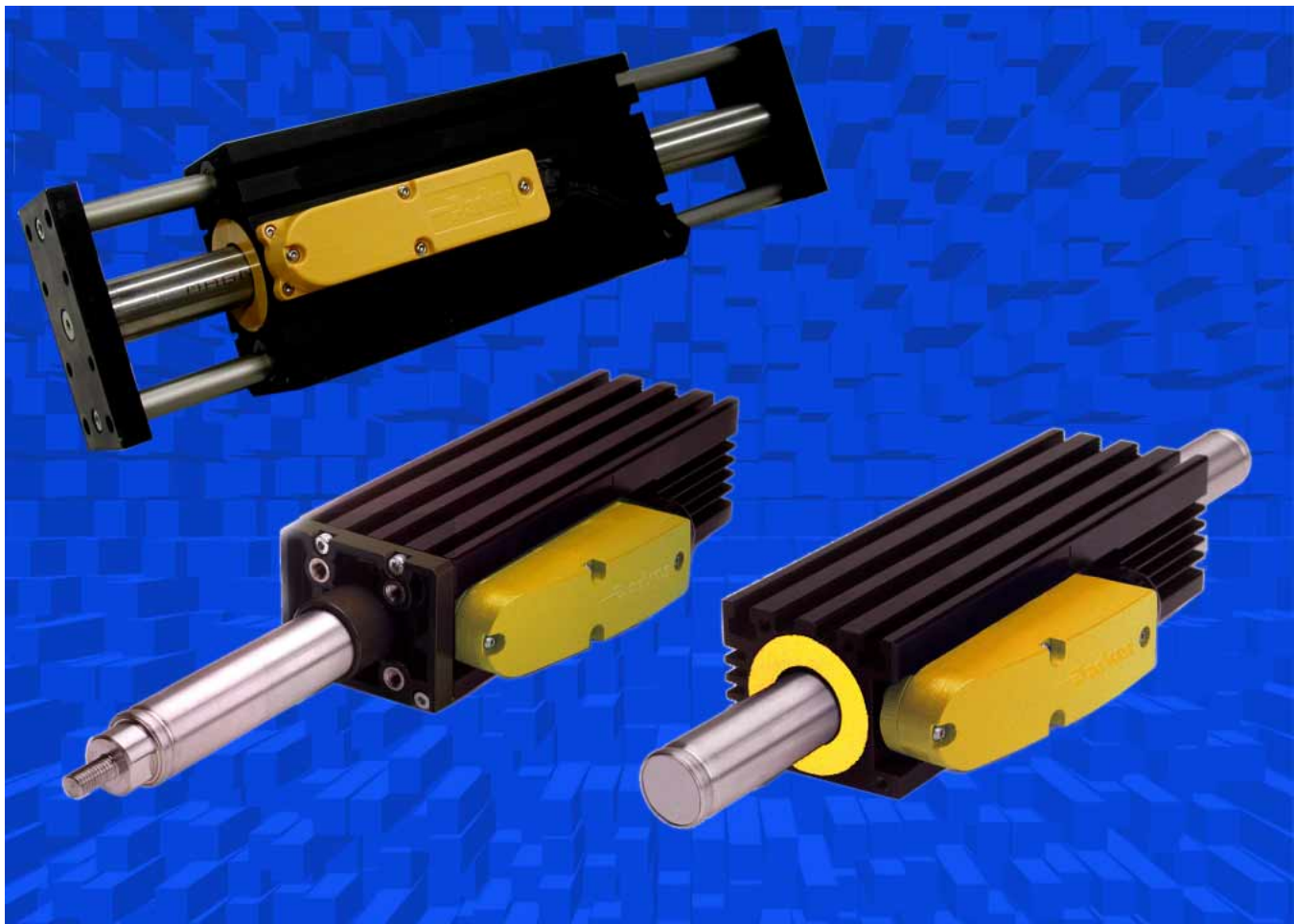

# *PowerRod*

*Actuators and components*

**Catalog: 192-570006 N2 / UK**  
**Version 2, January 2006**



# PowerRod: Actuators and components

## Contents

<b>PowerRod: Actuators and components .....</b>	<b>2</b>
<b>PowerRod: Actuators and components .....</b>	<b>3</b>
Overview .....	4
PowerRod PRA25, PRC25 .....	8
PowerRod with outrigger bearings PRR25 .....	13
PowerRod PRA38, PRC38 .....	18
Motor and feedback cable .....	23
Ambient conditions .....	23
Temperature sensor .....	23
Position sensor .....	24
Accessories .....	25
Order code.....	26

# PowerRod: Actuators and components

## PRA, PRC

The PowerRod actuators PRA and PRR25 with outrigger bearings as well as the PowerRod components PRC consist of a primary element in IP67 and a stainless steel magnet rod containing rare earth magnets.

The PRA and PRC are available in 2 different sizes and 4 versions and offer a continuous force of 51 up to 276N with peak forces of up to 1860N. PRA is available with strokes from 12 to 318mm and PRC is available with strokes of up to 1362mm (special sizes up to 2m are possible on request).

## PRR

The PRR25 is available in 4 versions and offers a continuous force of 61 to 119N with peak forces of up to 860N. The PRR is available with strokes ranging from 28 to 310 mm.

The PRR25 PowerRod actuator with outrigger bearings is available in a steel rods in ball linings or aluminium rods in polymer slidings bearings.

No external measuring system is required. The integrated position sensor provides analog sine and cosine differential input.

Parker Hannifin offers a wide range of powerful servo controllers. In particular the devices from the Compax3 family. All devices support easy setup and can be integrated into existing automation solutions.

## Overview

### General

#### ⇒ Sizes

- ◆ PRA magnet rod diameter: 25mm or 38mm
- ◆ PRC magnet rod diameter: 25mm or 38mm
- ◆ PRR magnet rod diameter: 25mm

#### ⇒ 3 types:

- ◆ PRA: Moving thrust rod
- ◆ PRC: Moving forcer
- ◆ PRR: Moving thrust rod with outrigger bearings

#### ⇒ 51 to 276N continuous force

#### ⇒ 312 to 1,860N peak force

#### ⇒ Integrated robust position sensor – no external measuring system required

#### ⇒ Standard feedback output

#### ⇒ Plug-and-play position control with all common servo controllers

#### ⇒ IP67 rating

### The OEM Benefits

#### ⇒ Clean, quiet operation

#### ⇒ Suitable for the food industry

#### ⇒ Simple installation

#### ⇒ Simple integration

#### ⇒ Industry standard accessories according to DIN/ISO 6431

#### ⇒ Low maintenance

### Applications

#### ⇒ Packaging

#### ⇒ Material Handling

#### ⇒ Automated Assembly

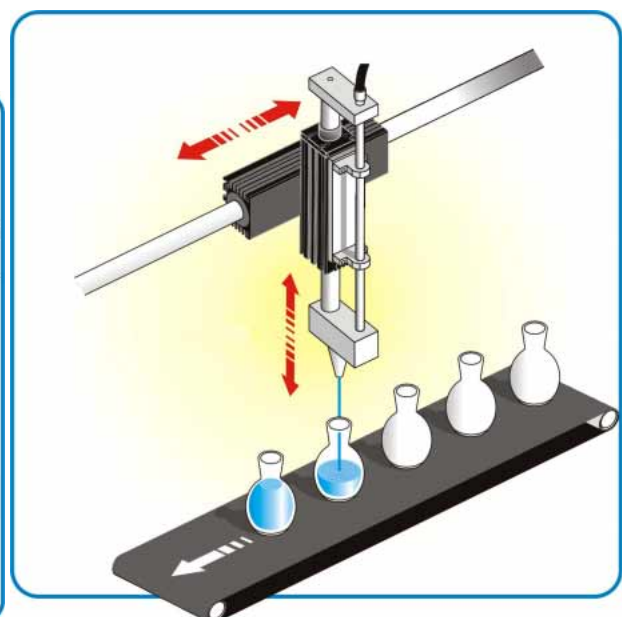
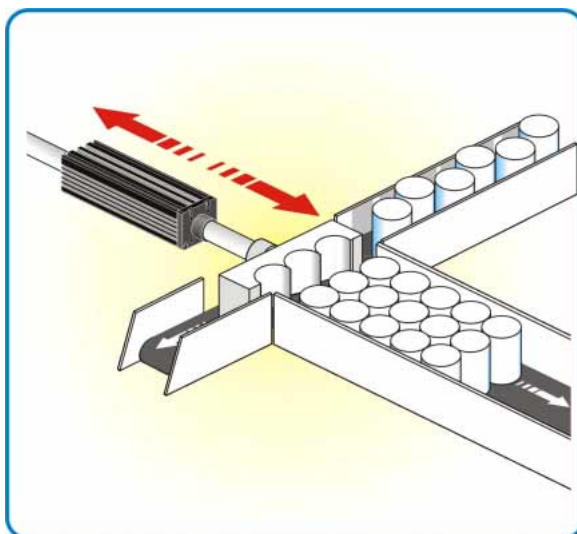

## PowerRod Actuator (PRA):

The PRA PowerRod Actuator was developed for the use in industrial automation systems, where different positions must be approached. The PRA linear motor drive is a cost-effective alternative to air cylinders in applications requiring greater flexibility and control. The PRA is ideal for push/pull/lift material handling, packaging and automated assembly applications. Mounting is compatible with all pneumatic industry fittings. An internal dry bearing provides clean, quiet, maintenance-free performance. Its service life is far longer than that of typical ballscrew solutions. The PRA has superior thermal efficiency due to the heat dissipation in all directions. Long operating cycles are possible without additional cooling.



PRA25



PRA38

⇒ **Moved magnet rod**

⇒ **Continuous force**

- ◆ PRA25: 51 ... 102N
- ◆ PRA38: 137 ... 276N

⇒ **Peak force**

- ◆ PRA25: 312 ... 780N
- ◆ PRA38: 744 ... 1,860N

⇒ **Stroke:**

- ◆ PRA25: 27 ... 309mm
- ◆ PRA38: 33 ... 318

⇒ **Speed\***

- ◆ PRA25: up to 5.9m/s
- ◆ PRA38: up to 5.3m/s

⇒ **Acceleration\*\***

- ◆ PRA25: up to 586m/s<sup>2</sup>
- ◆ PRA38: up to 391m/s<sup>2</sup>

⇒ **Integral, long-life, quiet, dry-running bearing**

⇒ **Clean, quiet operation (dry plastic bearing)**

⇒ **Accepts a range of industry standard mounting accessories**

⇒ **Integrated position sensor – no external linear measuring system required**

\*based on triangular move over maximum stroke, without payload; individually max. possible **velocities** (see on page 8, see on page 18).

\*\* based on a 27mm or 33mm stroke, without payload.

## PowerRod actuator with outrigger bearings (PRR25)

The outrigger bearings of the PRR actuator makes it the ideal solution for applications requiring an anti-rotational device and where lateral forces occur. The external bearing rails with ball bushings function as guiding for the moved magnet rod. Those steel gearing rails with ball bushings offer maximum support against high lateral forces. Polymer bushings use aluminium rails for reduced weight and are ideal for vertical loads. The iron-sleeve design of the PRR primary component produces 10 to 20% more force than actuator PRA25. The patented magnetic design of PRR generates a good repeatability from an integral position sensor. No external linear measuring system is required. The sensor provides analog sine and cosine differential input.

PRR is a ideal OEM solution for easy integration into pick-and-place gantries and general purpose material handling machines. The load is mounted directly to the mounting plate. PRR has superior thermal efficiency, radiating heat uniformly. Long operating cycles are possible without additional cooling.



PRR25

- ⇒ **Moved magnet rod**
- ⇒ **Continuous force**
  - ◆ PRR25: 61 ... 119N
- ⇒ **Peak force**
  - ◆ PRR25: 344 ... 860N
- ⇒ **Stroke:**
  - ◆ PRR25: 28 ... 310mm
- ⇒ **Speed\***
  - ◆ PRR25: up to 5.6m/s
- ⇒ **Acceleration\*\***
  - ◆ PRR25: up to 369m/s<sup>2</sup>
- ⇒ **Integrated position sensor – no external linear measuring system required**

\*based on triangular move over maximum stroke, without payload; individually max. possible **velocities with the ball bushing option** (see on page 13)

\*\* based on a 28mm stroke, without payload. Ball bushing option

## PowerRod Component: Primary component PRC and magnet rod TRC

PowerRod (PRC + TRC) can be compared to a pneumatic cylinder without thrust rod, it is however much easier to install and is as reliable as a linear motor. Familiar form factor, integral position feedback and large air gap make integration simple.

PowerRod is the ideal solution for integration in pick-and-place gantries and general purpose handling systems. The load is mounted directly to the forcer typically supported by a single bearing rail. The thrust rod is mounted level at both end, the primary component is mounted on a suitable guiding. A large air gap reduces alignment constraints.

The tubular motor has superior thermal efficiency, radiating heat uniformly. High duty cycles are possible without the need for forced-air or water cooling.



PRC25 with TRC25



PRC38 with TRC38

⇒ **Moving forcer**

⇒ **Continuous force**

- ◆ PRC25: 51 ... 102N
- ◆ PRC38: 137 ... 276N

⇒ **Peak force**

- ◆ PRC25: 312 ... 780N
- ◆ PRC38: 744 ... 1,860N

⇒ **Stroke:**

- ◆ PRC25: 27 ... 1,180mm
- ◆ PRC38: 33 ... 1,362mm

⇒ **Speed\***

- ◆ PRC25: up to 8.7m/s
- ◆ PRC38: up to 9.4m/s

⇒ **Acceleration\*\***

- ◆ PRC25: up to 256m/s<sup>2</sup>
- ◆ PRC38: up to 307m/s<sup>2</sup>

⇒ **Compact design for simple mechanical integration**

⇒ **Large air gap**

⇒ **Mount load directly to rugged forcer**

⇒ **No additional cooling required – specifications for convection**

⇒ **Integrated position sensor – no external linear measuring system required**

\*based on triangular move over maximum stroke, without payload; individually max. possible **velocities** (see on page 8, see on page 18).

\*\* based on a 27mm or 33mm stroke, without payload.



## PowerRod PRA25, PRC25

### Electric specifications PRA25, PRC25

Motor type PRA, PRC	2504		2506		2508		2510		Unit
	S (1)	P (1)	S (1)	P (1)	S (1)	P (1)	S (1)	P (1)	
Peak force (5) for 1 sec	312	156	468	234	624	312	780	390	N
Peak current (5) for 1 sec	14.1		14.1		14.1		14.1		Aeff
With 25x25x2.5cm heatsink plate (6)									
Continuous stall force (5) (2)	51.2		69.5		86.4		102.4		N
Continuous stall current (5)	2.31	4.62	2.10	4.20	1.96	3.92	1.86	3.72	Aeff
Without heatsink plate									
Continuous stall force (5) (2)	42.5		59.5		75.1		90.0		N
Continuous stall current (5)	1.92	3.84	1.80	3.60	1.70	3.40	1.63	3.26	Aeff
Force constant (sine commutation)	22.1	11.0	33.1	16.5	44.1	22.0	55.2	27.6	N/Aeff
Back EMF constant (phase to phase)	18.0	9.0	27.0	13.5	36.0	18.0	45.0	22.5	V/m/s
Fundamental motor constant	6.47		7.92		9.13		10.24		N/\W
Eddy current loss	9.51		12.55		15.58		18.61		N/m/s
Resistance @ 25°C (phase to phase)	6.02	1.50	9.02	2.25	12.03	3.01	15.04	3.76	Ohm
Resistance @ 100°C (phase to phase)	7.75	1.94	11.63	2.91	15.51	3.88	19.39	4.85	Ohm
Inductance @ 1kHz (phase to phase)	3.90	0.97	5.85	1.46	7.80	1.95	9.75	2.44	mH
Electrical time constant	0.65		0.65		0.65		0.65		ms
Typical supply voltage of the servo drive	230		230		230		230		VAC
Max. DC bus voltage	380		380		380		380		V d.c.
Pole pitch	51.2		51.2		51.2		51.2		mm
<b>PRA</b>									
Peak acceleration (3)	394	197	483	241	542	271	586	293	m/s <sup>2</sup>
Maximum speed (4)	5.9	4.4	5.3	5.1	4.7	5.6	4.2	5.8	m/s
<b>PRC</b>									
Peak acceleration (7)	223	111	223	111	235	117	256	128	m/s <sup>2</sup>
Maximum speed (4)	8.7	7.3	6.5	7.2	5.4	7.6	4.6	7.0	m/s

- (1) S=series motor phases, P=parallel motor phases
- (2) Reduce continuous stall force to 89% at 40°C ambient
- (3) Based on a 27mm stroke, without payload
- (4) Based on triangular move over maximum stroke, without payload
- (5) At 25°C ambient temperature
- (6) The values with normalized heatsink plate are meant to give indications to the data valid if the forcer is integrated into a machine.
- (7) Moved primary element, without payload.

### Thermal specifications PRA25, PRC25

Motor type PRA, PRC	2504	2506	2508	2510	Unit
Maximum phase temperature	100	100	100	100	°C
Thermal resistance Rth (phase-housing)	0.41	0.27	0.20	0.16	°C/W
Thermal time constant	1188	1276	1377	1486	s
With 25x25x2.5cm heatsink plate (6)					
Power dissipation @ 25°C ambient	62.3	77.0	89.2	100.2	Watt
Thermal resistance Rth (housing-environment)	0.79	0.69	0.64	0.59	°C/W
Without heatsink plate					
Power dissipation @ 25°C ambient	43.1	56.4	67.6	77.3	Watt
Thermal resistance Rth (housing-environment)	1.33	1.06	0.91	0.81	°C/W

(6) The values with normalized heatsink plate are meant to give indications to the data valid if the forcer is integrated into a machine.



**Mechanical specifications PRA25, PRC25**

**Dimensions PRA25 (third angle projection)**

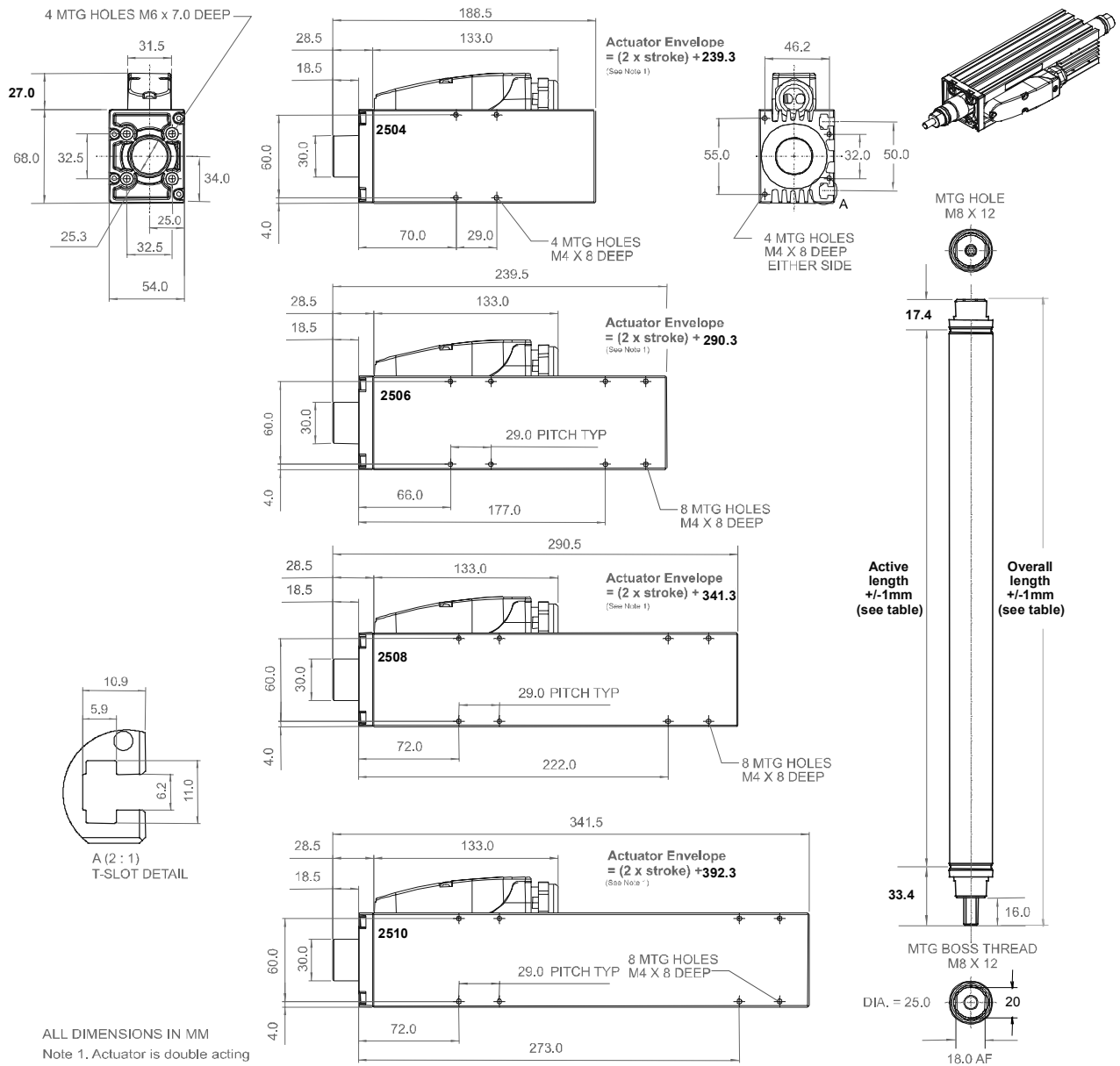

3D-CAD Data <http://www.parker.com/ead/cm2.asp?cmid=9005>

Motor Type	PRA2504	PRA2506	PRA2508	PRA2510	Unit
Maximum stroke	309	309	309	309	mm
Forcer mass	1.25	1.70	2.25	2.65	kg
Mass of rod	3.5	3.5	3.5	3.5	kg/m

**Length of the magnet rod TRA25 in PRA25**

Stroke (mm)	PRA2504		PRA2506		PRA2508		PRA2510	
	Gesamt Overall	Aktiv Active	Gesamt Overall	Aktiv Active	Gesamt Overall	Aktiv Active	Gesamt Overall	Aktiv Active
27	266	216	317	267	368	318	419	369
53	292	242	343	293	394	344	445	395
78	317	267	368	318	419	369	470	420
104	343	293	394	344	445	395	496	446
130	369	319	420	370	471	421	522	472
155	394	344	445	395	496	446	547	497
181	420	370	471	421	522	472	573	523
206	445	395	496	446	547	497	598	548
232	471	421	522	472	573	523	624	574
258	497	447	548	498	599	549	650	600
283	522	472	573	523	624	574	675	625
309	548	498	599	549	650	600	701	651

Dimensions PRC25 (third angle projection)

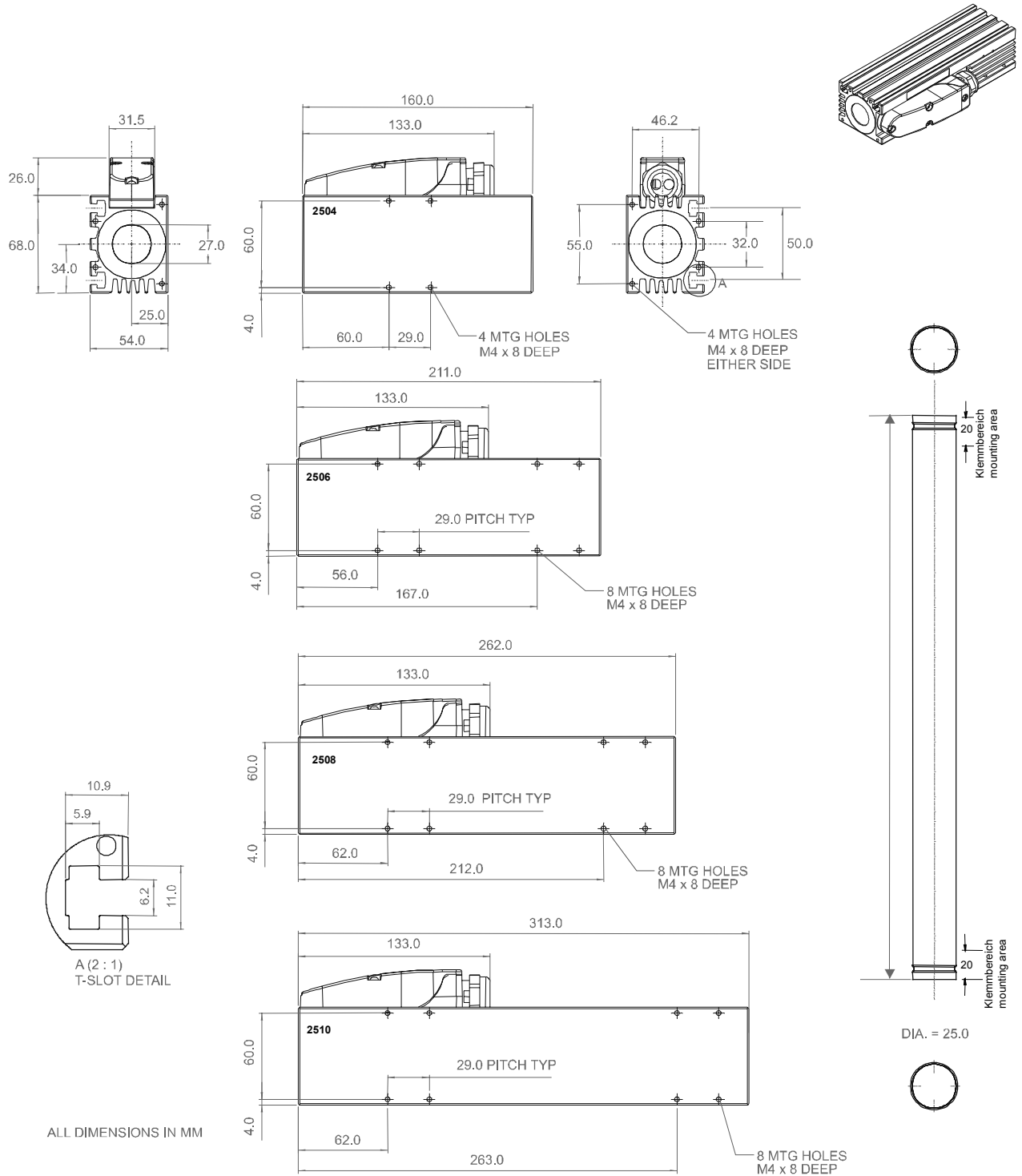

3D-CAD-Data <http://www.parker.com/ead/cm2.asp?cmid=8976>

Motor Type	PRC2504	PRC2506	PRC2508	PRC2510	Unit
Maximum stroke	1180	1129	1078	1027	mm
Forcer mass	1.15	1.60	2.15	2.55	kg
Rod mass/metre	3.5	3.5	3.5	3.5	kg/m

**Possible lengths of the magnet rod TRC25 for PRC25 (in mm)**

0226	0354	0482	0611	0739	0918	1175
0252	0380	0508	0636	0765	0970	1226
0277	0405	0534	0662	0790	1021	1278
0303	0431	0559	0688	0816	1072	1329
0329	0457	0585	0713	0867	1124	1380

**Force / velocity profiles PRA25**

**Force/velocity profiles (with an operating voltage of 325Vd.c., without load)**

**S=series motor phases**

**P=parallel motor phases**

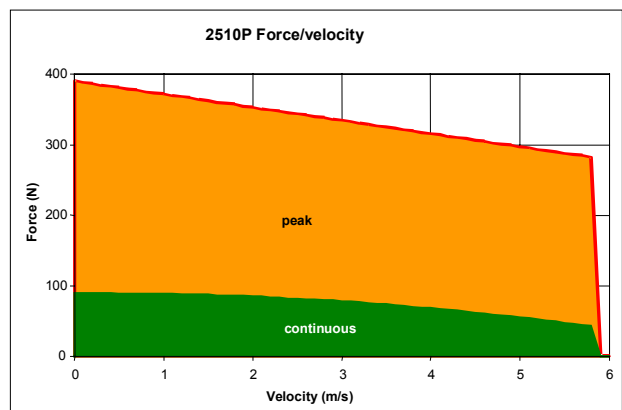
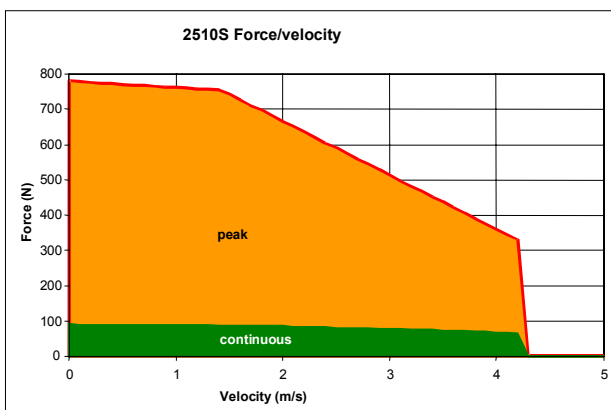
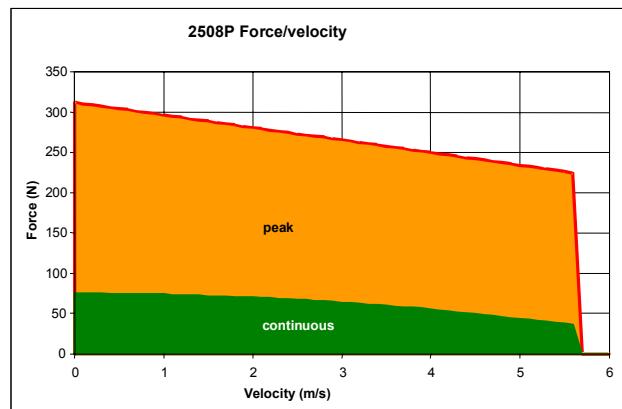
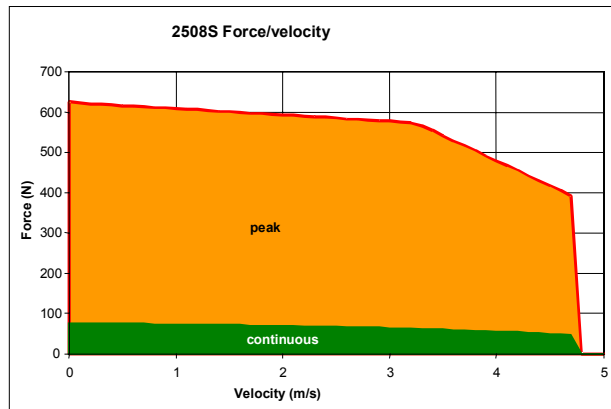
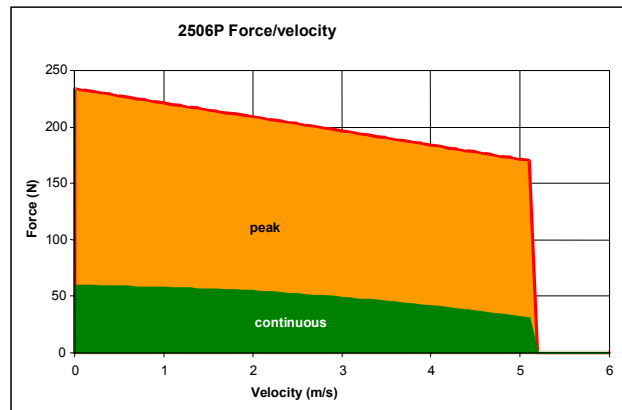
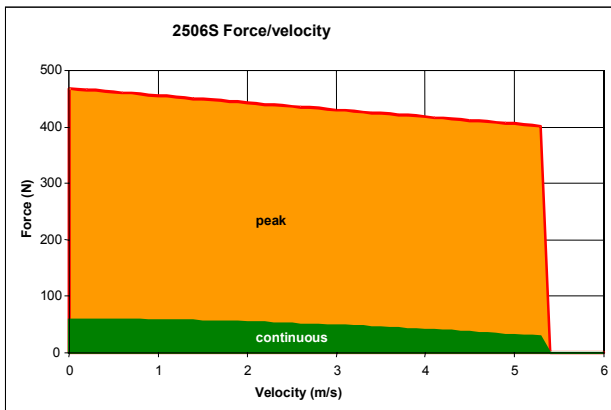
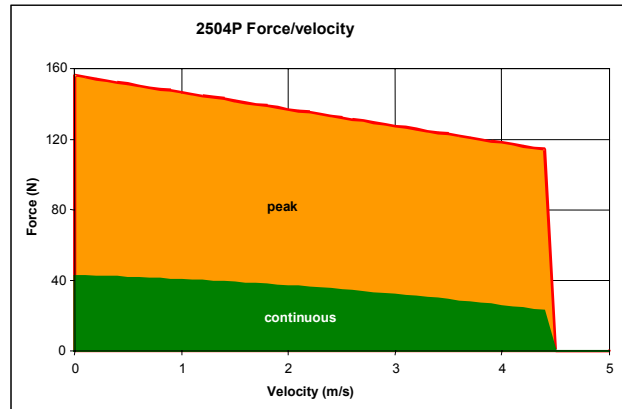
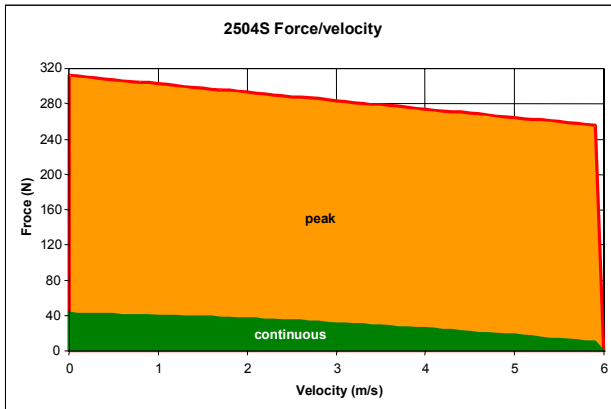

**Force / velocity profiles PRC25**

**Force/velocity profiles (with an operating voltage of 325Vd.c., without load)**

**S=series motor phases**

**P=parallel motor phases**

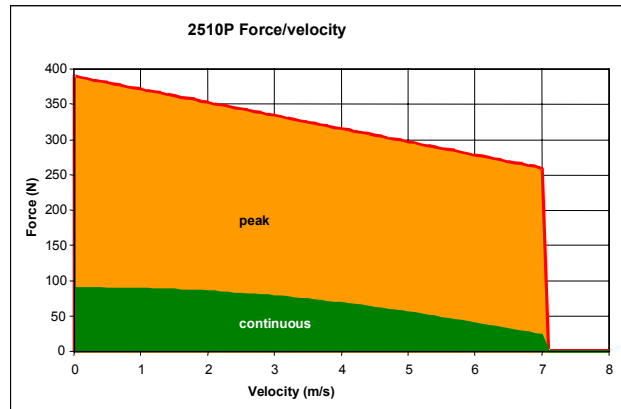
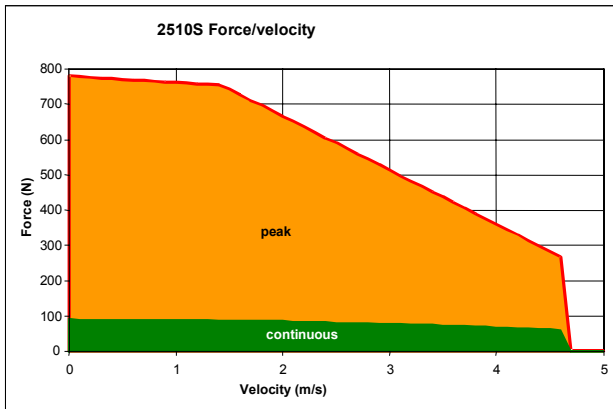
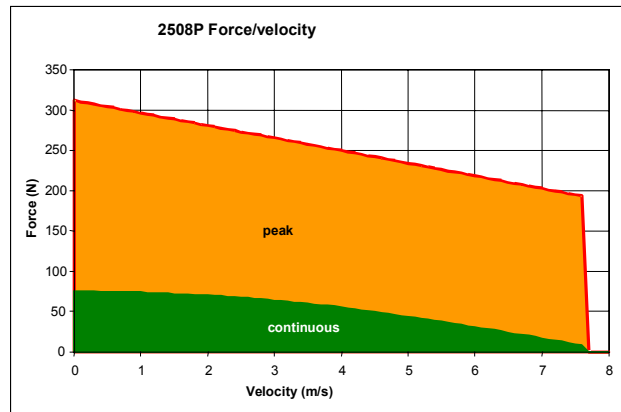
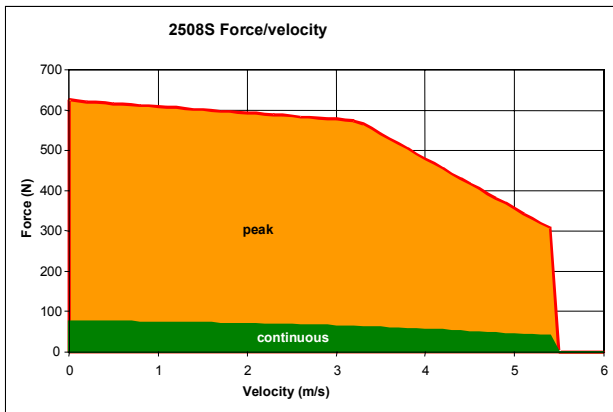
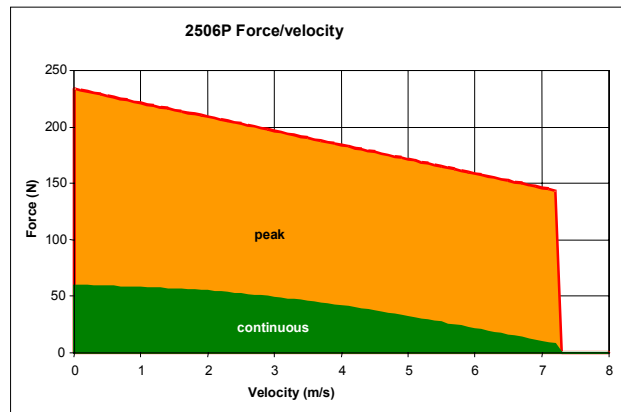
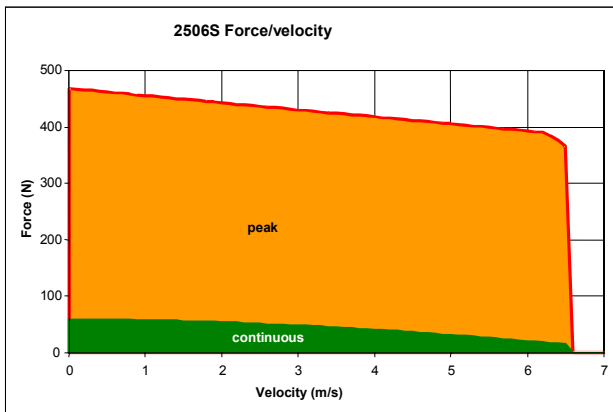
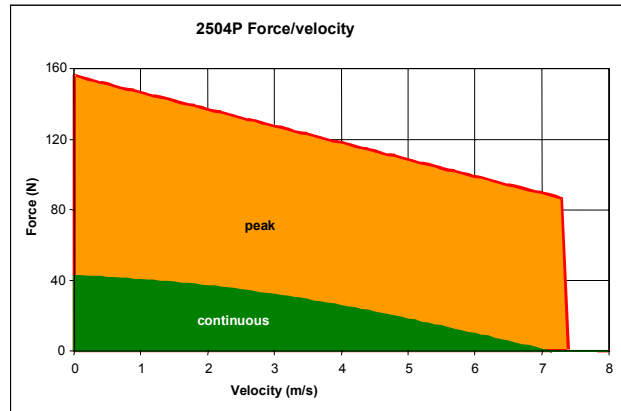
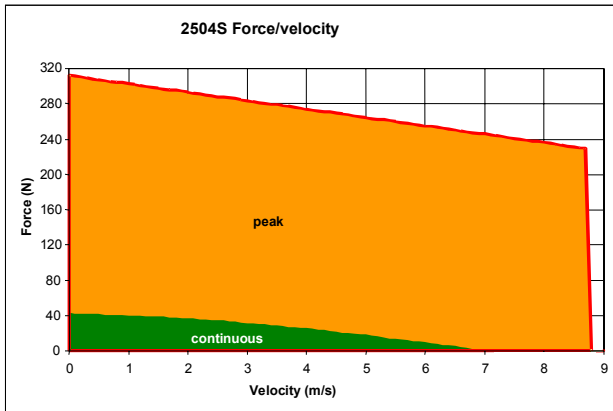

## PowerRod with outrigger bearings PRR25

### Electric specifications PRR25

Motor type PRR	2504		2506		2508		2510		Unit
	S (1)	P (1)	S (1)	P (1)	S (1)	P (1)	S (1)	P (1)	
Peak force (5) for 1 sec	344	172	516	258	688	344	860	430	N
Peak current (5) for 1 sec	14.1		14.1		14.1		14.1		Aeff
With 25x25x2.5cm heatsink plate									
Continuous stall force (2)	60.7		81.8		101.2		119.4		N
Continual stall current	2.49	4.98	2.24	4.48	2.08	4.16	1.96	3.92	Aeff
Without heatsink plate									
Continuous stall force (2)	52.2		72.3		90.4		108.0		N
Continual stall current	2.15	4.30	1.98	3.96	1.86	3.72	1.78	3.56	Aeff
Force constant (sine commutation)	24.3	12.1	36.5	18.2	48.6	24.3	60.8	30.4	N/Aeff
Back EMF constant (phase - phase)	19.9	9.9	29.8	14.9	39.7	19.8	49.7	24.8	V/m/s
Fundamental motor constant	7.53		9.22		10.65		11.90		N/√W
Eddy current loss	2.35		2.35		2.35		2.35		N/m/s
Cogging force	2.2		3.2		3.3		3.0		+/-N
Resistance @ 25°C (phase - phase)	5.40	1.35	8.11	2.03	10.81	2.70	13.51	3.38	Ohm
Resistance @ 100°C (phase - phase)	6.96	1.74	10.45	2.61	13.93	3.48	17.41	4.35	Ohm
Inductance @ 1kHz (phase to phase)	4.32	1.08	6.48	1.62	8.64	2.16	10.80	2.70	mH
Electrical time constant	0.80		0.80		0.80		0.80		ms
Typical supply voltage of servo drive	230		230		230		230		VAC
Max. DC bus voltage	380		380		380		380		V d.c.
Pole pitch	51.2		51.2		51.2		51.2		mm
with steel rods in ball linings									
Peak acceleration (3) (5)	225	113	288	144	334	167	369	185	m/s <sup>2</sup>
Maximum speed (4) (5)	5.6	4.1	5.3	5.0	4.8	5.5	4.3	5.8	m/s
with aluminium rods and sliding bushings									
Peak acceleration (3) (6)	276	138	354	177	413	206	458	229	m/s <sup>2</sup>
Maximum speed (4) (6)	6.1	4.6	5.7	5.5	5.1	6.2	4.5	6.3	m/s

- (1) S=series motor phases, P=parallel motor phases  
(2) Reduce continuous stall force to 89% at 40°C ambient  
(3) Based on a 28mm stroke, without payload  
(4) Based on triangular move over maximum stroke, without payload  
(5) -B = with ball bushings  
(6) -P = with sliding bushings

### Thermal specifications PRR25

Motor type PRR	2504	2506	2508	2510	Unit
Maximum phase temperature	100	100	100	100	°C
Thermal resistance Rth (phase-housing)	0.39	0.28	0.23	0.19	°C/W
Thermal time constant	1639	1773	1940	2080	s
With 25x25x2.5cm heatsink plate					
Power dissipation @ 25°C ambient	65.0	78.8	90.4	100.6	Watt
Thermal resistance Rth (housing-environment)	0.76	0.67	0.60	0.56	°C/W
Without heatsink plate					
Power dissipation @ 25°C ambient	48.1	61.5	72.1	82.4	Watt
Thermal resistance Rth (housing-environment)	1.17	0.94	0.81	0.72	°C/W

**Mechanical specifications PRR25**

**Dimensions PRR25 (third angle projection)**

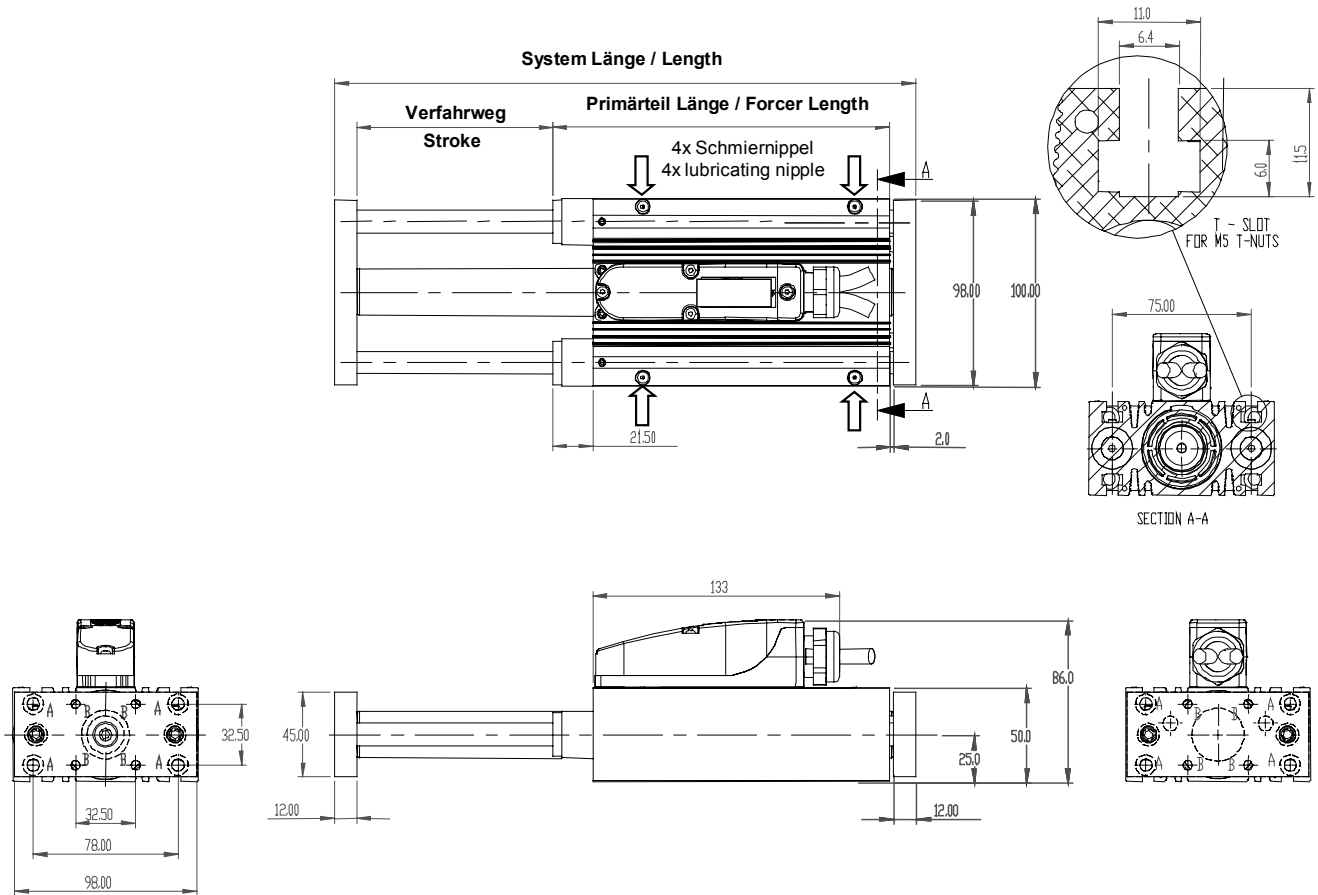

Holes in the end plates:

O	Hole: Ø 6.6mm; Countersink for cylinder head screw Ø 11mm, depth 6.5mm
B	M6

Motor Type	PRR2504	PRR2506	PRR2508	PRR2510	Unit
Maximum stroke	310	310	310	310	mm
Length of primary element	181.5	232.5	283.5	334.5	mm
Forcer mass	1.65	2.25	2.85	3.45	kg
Mass of rod (ball bushings)	0.25 + (total length in m x 5.24)				kg
Mass of rod (polymer sliding bushings)	0.25 + (total length in m x 4.10)				kg

Stroke (mm)	System length PRR (mm)			
	PRR2504	PRR2506	PRR2508	PRR2510
28	236	287	338	389
54	262	313	364	415
79	287	338	389	440
105	313	364	415	466
131	339	390	441	492
156	364	415	466	517
182	390	441	492	543
207	415	466	517	568
233	441	492	543	594
259	467	518	569	620
284	492	543	594	645
310	518	569	620	671

**Mechanical stiffness PRR25**

The deflection values were measured and contain also the compliance of the bushings.

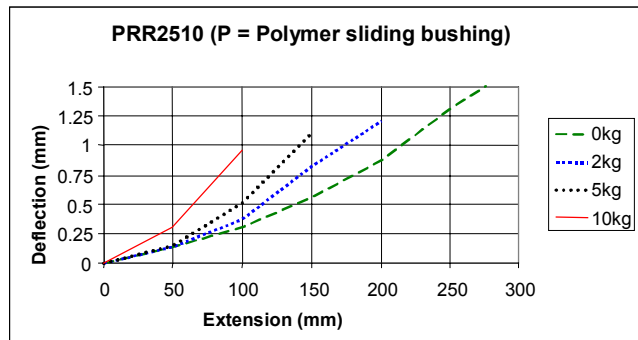
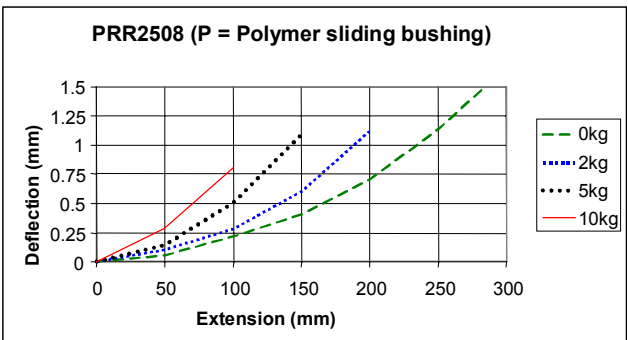
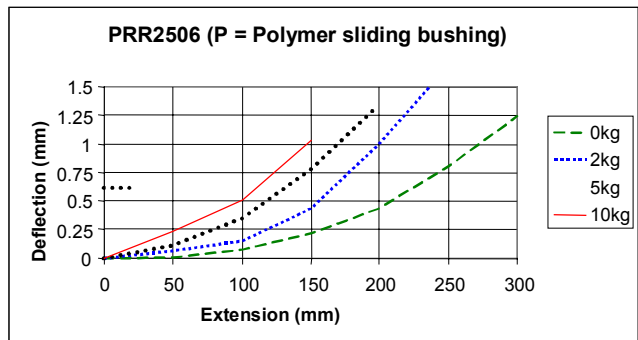
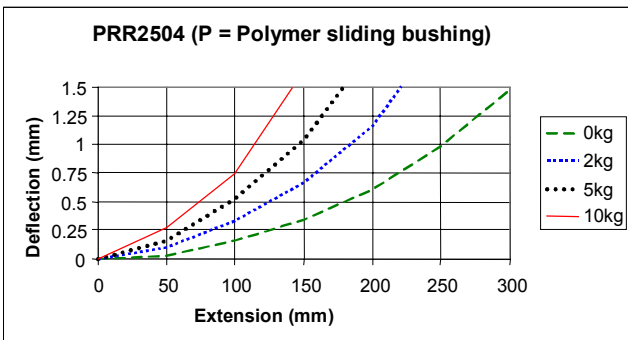
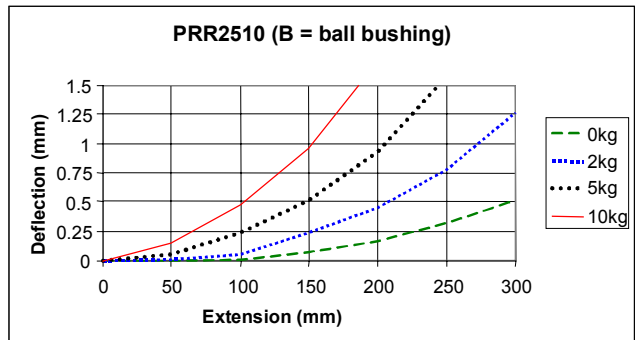
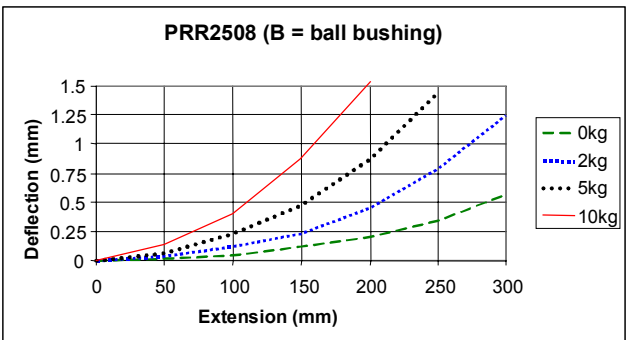
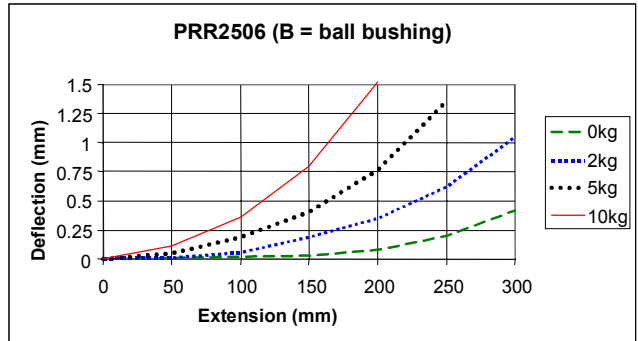
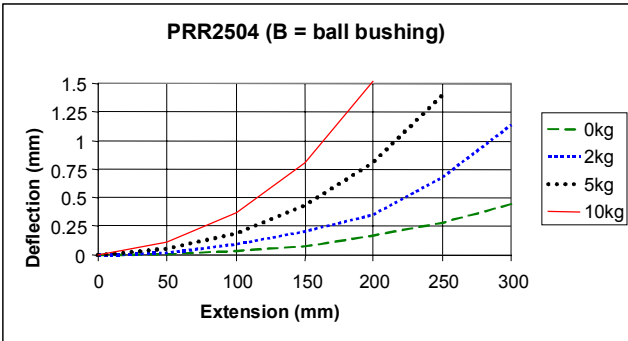
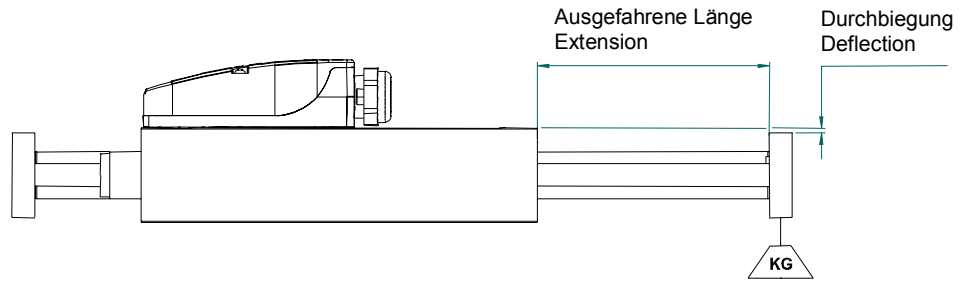



Comparison of payload and extension with a operational performance of 10,000km

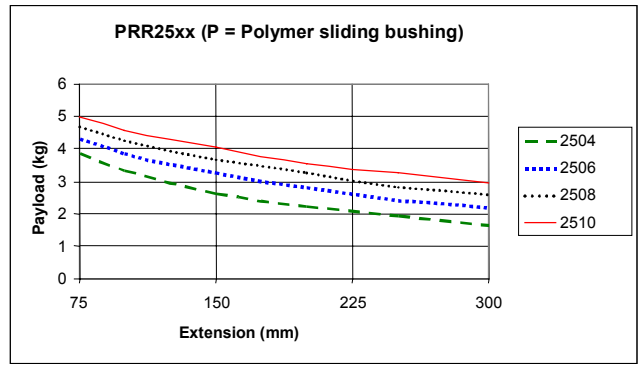
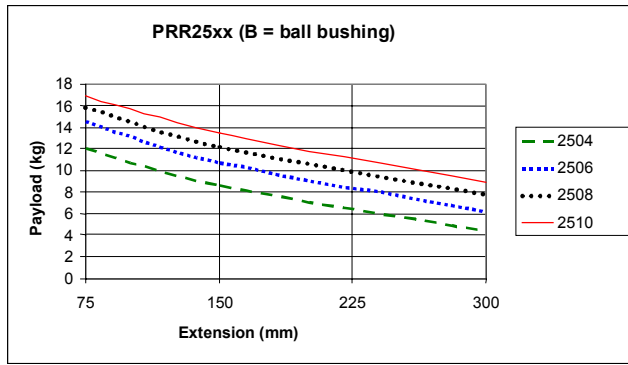

**Force / velocity profiles PRR25**

Force/velocity profiles (with an operating voltage of 325Vd.c., without load)

S=series motor phases

P=parallel motor phases

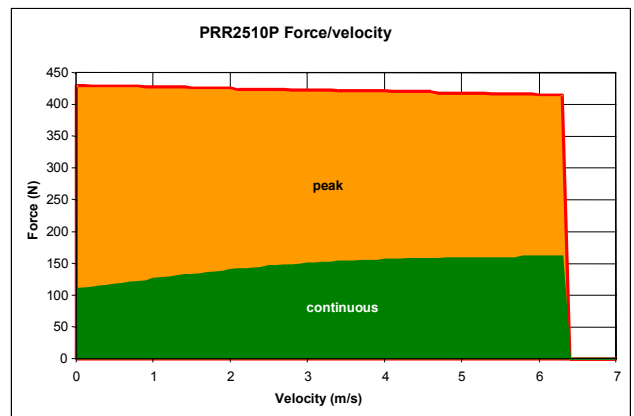
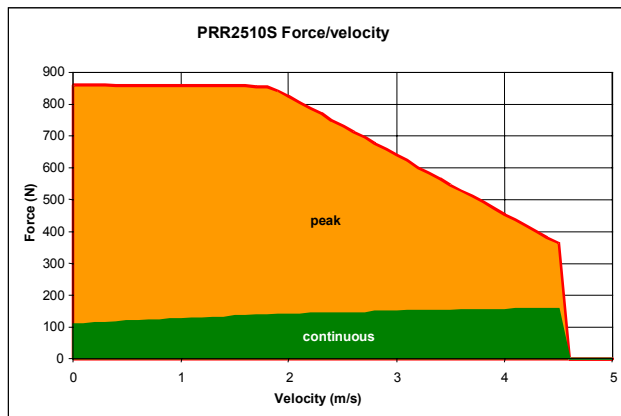
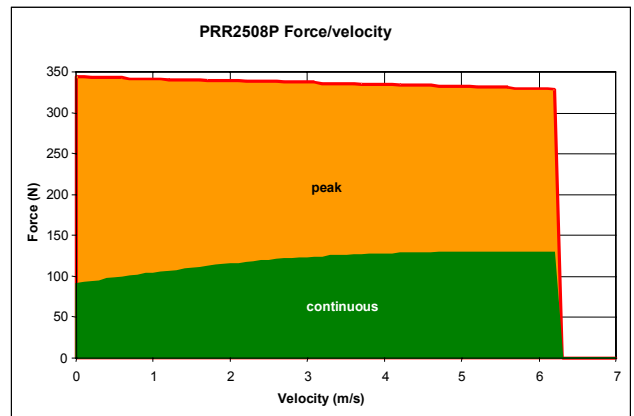
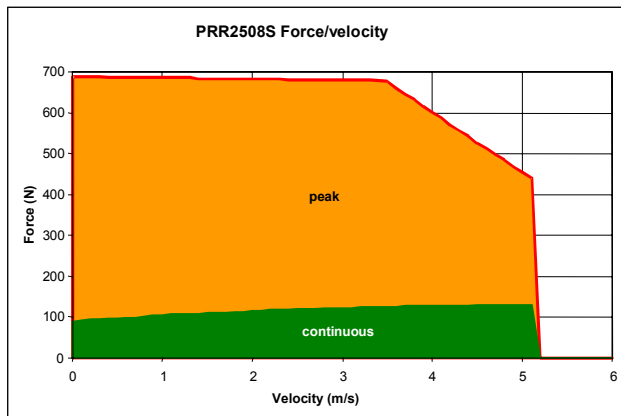
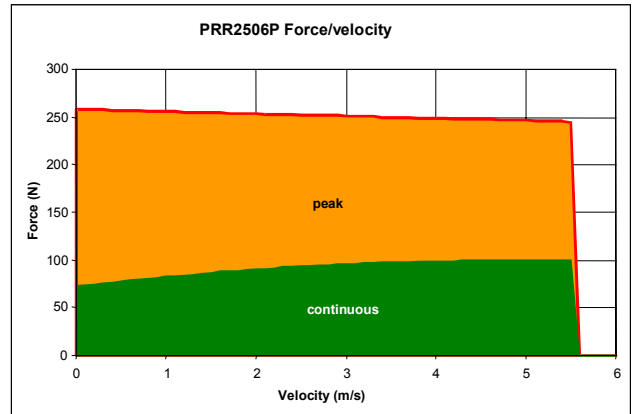
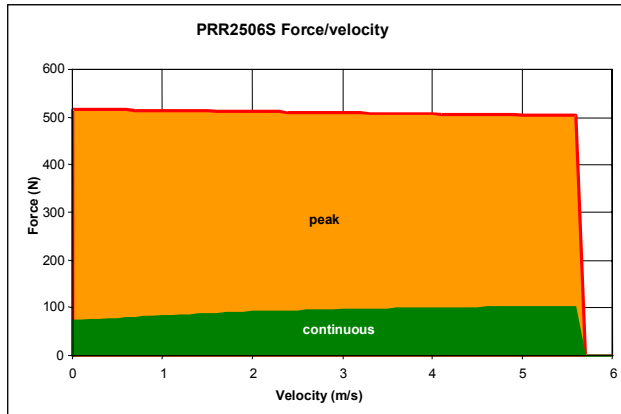
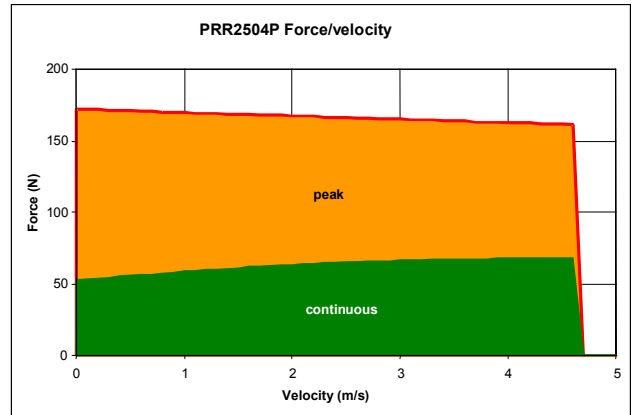
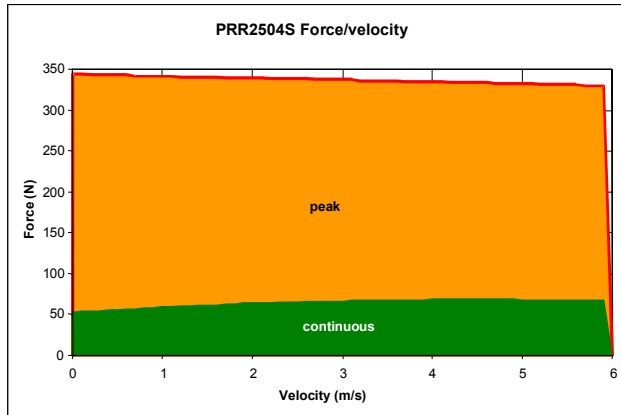

## PowerRod PRA38, PRC38

### Electric specifications PRA38, PRC38

Motor type PRA38, PRC38	3804		3806		3808		3810		Unit
	S (1)	P (1)	S (1)	P (1)	S (1)	P (1)	S (1)	P (1)	
Peak force (5) for 1 sec	744	372	1116	558	1488	744	1860	930	N
Peak current (5) for 1 sec	14.1		14.1		14.1		14.1		Aeff
With 25x25x2.5cm heatsink plate (6)									
Continuous stall force (5) (2)	137.3		186.9		232.1		276.2		N
Continuous stall current (5)	2.61	5.23	2.37	4.74	2.20	4.41	2.10	4.20	Aeff
Without heatsink plate									
Continuous stall force (5) (2)	120.1		168.2		212.7		255.0		N
Continuous stall current (5)	2.28	4.57	2.13	4.27	2.02	4.04	1.94	3.88	Aeff
Force constant (sine commutation)	52.6	26.3	78.9	39.4	105.2	52.6	131.5	65.7	N/Aeff
Back EMF constant (phase - phase)	43.0	21.5	64.4	32.2	85.9	42.9	107.4	53.7	V/m/s
Fundamental motor constant	14.54		17.80		20.56		22.99		N/√W
Eddy current loss	3.7		3.7		3.7		3.7		N/m/s
Cogging force	7.3		4.2		8.3		5.6		+/-N
Resistance @ 25°C (phase - phase)	6.77	1.69	10.16	2.54	13.54	3.38	16.93	4.23	Ohm
Resistance @ 100°C (phase to phase)	8.73	2.18	13.10	3.27	17.45	4.36	21.82	5.45	Ohm
Inductance @ 1kHz (phase to phase)	8.52	2.13	12.78	3.19	17.04	4.26	21.30	5.32	mH
Electrical time constant	1.26		1.26		1.26		1.26		ms
Typical supply voltage of the servo drive	230		230		230		230		VAC
Max. DC bus voltage	380		380		380		380		V d.c.
Pole pitch	71.2		71.2		71.2		71.2		mm
<b>PRA</b>									
Peak acceleration (3)	250	125	313	156	357	179	391	196	m/s <sup>2</sup>
Maximum speed (4)	4.7	4.9	3.8	5.3	3.1	4.9	2.6	4.4	m/s
<b>PRC</b>									
Peak acceleration (7)	244	122	276	138	295	147	307	154	m/s <sup>2</sup>
Maximum speed (4)	6.2	9.4	4.5	7.6	3.5	6.2	2.8	5.2	m/s

- (1) S=series motor phases, P=parallel motor phases  
(2) Reduce continuous stall force to 89% at 40°C ambient  
(3) Based on a 33mm stroke, without payload  
(4) Based on triangular move over maximum stroke, without payload  
(5) At 25°C ambient temperature  
(6) The values with normalized heatsink plate are meant to give indications to the data valid if the forcer is integrated into a machine.  
(7) Moved primary element, without payload.

### Thermal specifications PRA38, PRC38

Motor type PRA38, PRC38	3804	3806	3808	3810	Unit
Maximum phase temperature	100	100	100	100	°C
Thermal resistance Rth (phase-housing)	0.23	0.16	0.13	0.11	°C/W
Thermal time constant	1677	1798	1924	2056	s
With 25x25x2.5cm heatsink plate (6)					
Power dissipation @ 25°C ambient	89.3	110.3	127.1	144.2	Watt
Thermal resistance Rth (housing-environment)	0.61	0.52	0.46	0.41	°C/W
Without heatsink plate					
Power dissipation @ 25°C ambient	67.2	89.3	107.0	123.0	Watt
Thermal resistance Rth (housing-environment)	0.87	0.68	0.57	0.50	°C/W

(6) The values with normalized heatsink plate are meant to give indications to the data valid if the forcer is integrated into a machine.

**Mechanical specifications PRA38, PRC38**

**Dimensions PRA38 (third angle projection)**

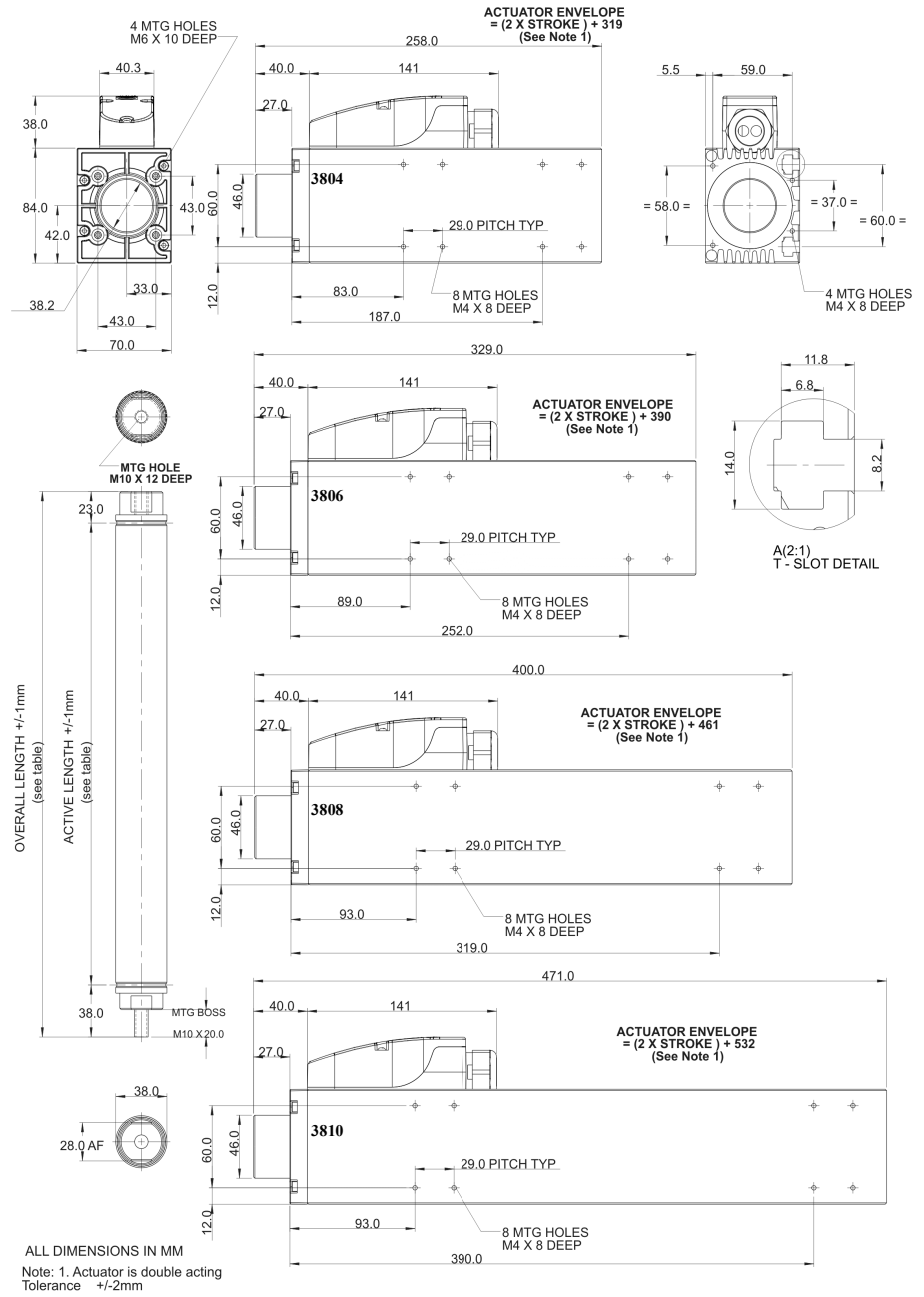

3D-CAD Data <http://www.parker.com/ead/cm2.asp?cmid=9005>

Motor Type	PRA3804	PRA3806	PRA3808	PRA3810	Unit
Maximum stroke	318	318	318	318	mm
Forcer mass	2.75	3.75	4.75	5.75	kg
Rod mass/metre	8.3	8.3	8.3	8.3	kg/m

**Length of the magnet rod TRA38 in PRA38**

Stroke (mm)	PRA3804		PRA3806		PRA3808		PRA3810	
	Gesamt Overall	Aktiv Active	Gesamt Overall	Aktiv Active	Gesamt Overall	Aktiv Active	Gesamt Overall	Aktiv Active
33	350	291	421	362	493	434	564	505
69	386	327	457	398	528	469	599	540
104	421	362	493	434	564	505	635	576
140	457	398	528	469	599	540	671	612
176	493	434	564	505	635	576	706	647
211	528	469	599	540	671	612	742	683
247	564	505	635	576	706	647	778	719
282	599	540	671	612	742	683	813	754
318	635	576	706	647	778	719	849	790

Dimensions PRC38 (third angle projection)

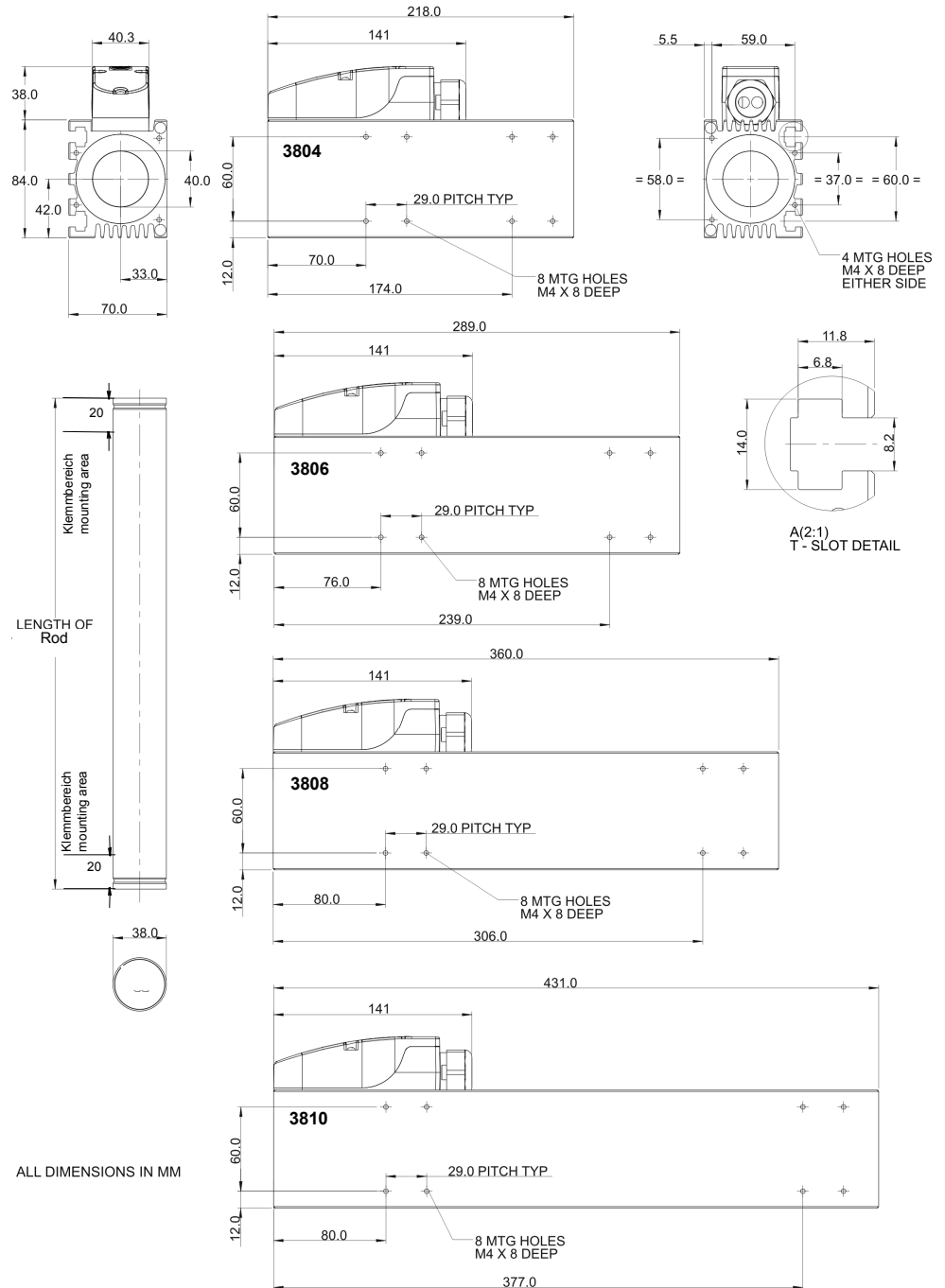

3D-CAD-Data <http://www.parker.com/ead/cm2.asp?cmid=8976>

Motor Type	PRC3804	PRC3806	PRC3808	PRC3810	Unit
Maximum stroke	1362	1291	1219	1148	mm
Forcer mass	2.55	3.55	4.55	5.55	kg
Rod mass/metre	8.3	8.3	8.3	8.3	kg/m

**Possible lengths of the magnet rod TRC38 for PRC38 (in mm)**

0265	0444	0622	0800	0978	1157	1335	1513
0301	0479	0657	0836	1014	1192	1370	1549
0337	0515	0693	0871	1050	1228	1406	1584
0372	0550	0729	0907	1085	1263	1442	1620
0408	0586	0764	0943	1121	1299	1477	

**Force / velocity profiles PRA38**

Force/velocity profiles (with an operating voltage of 325Vd.c., without load)

S=series motor phases

P=parallel motor phases

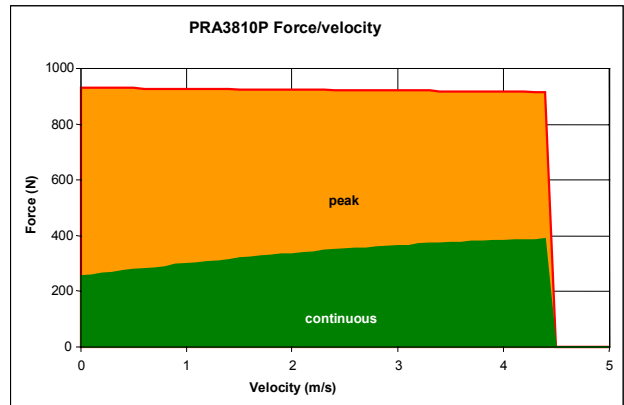
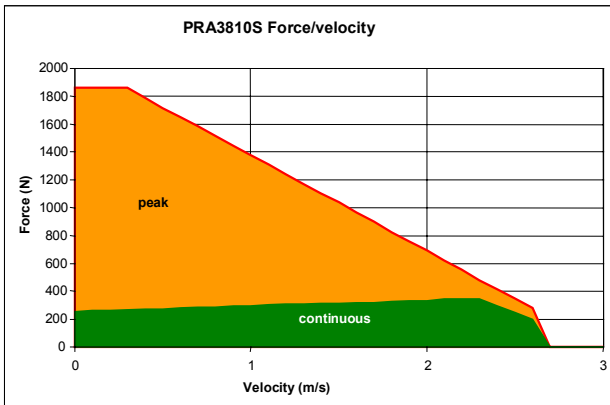
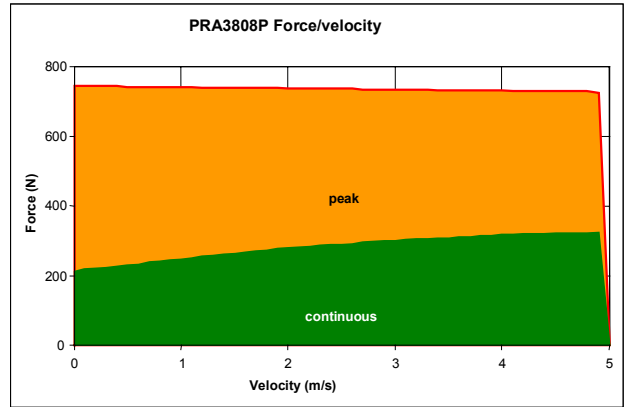
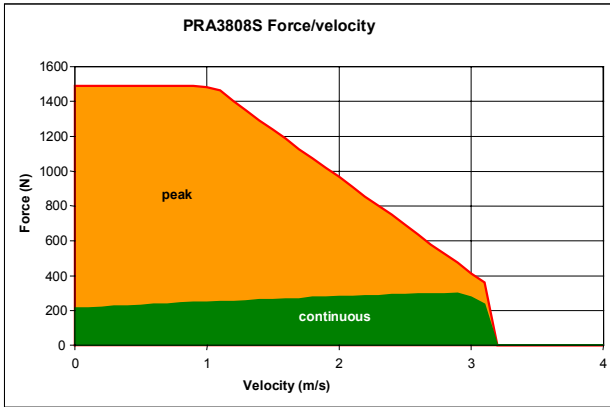
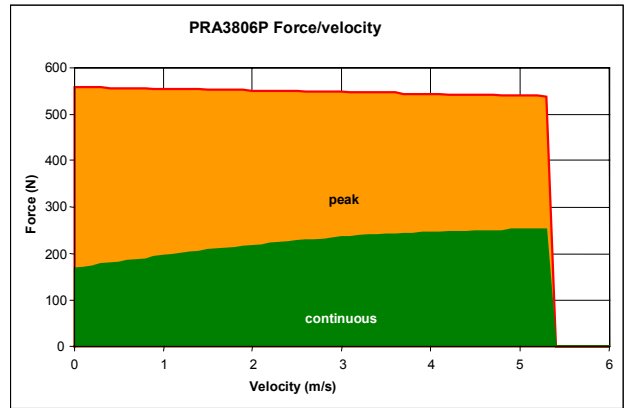
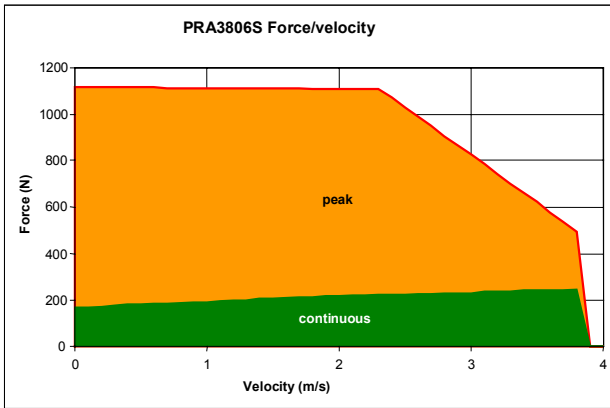
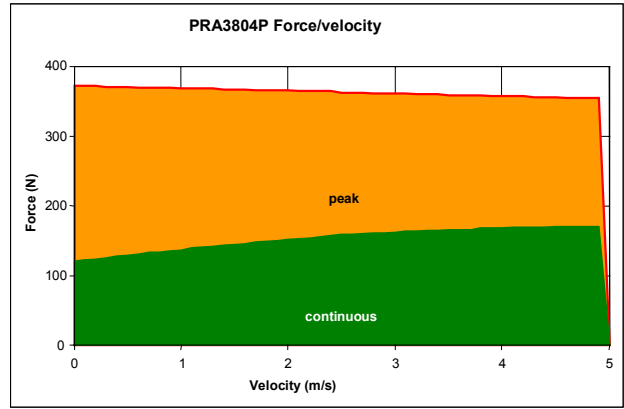
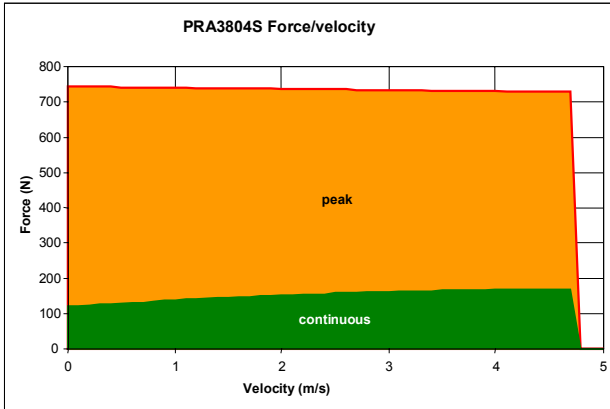

**Force / velocity profiles PRC38**

**Force/velocity profiles (with an operating voltage of 325Vd.c., without load)**

**S=series motor phases**

**P=parallel motor phases**

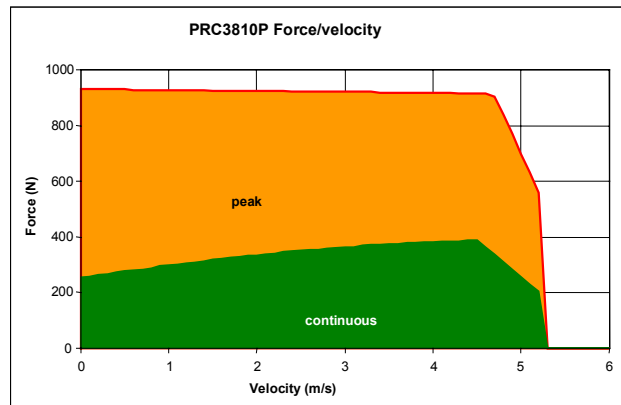
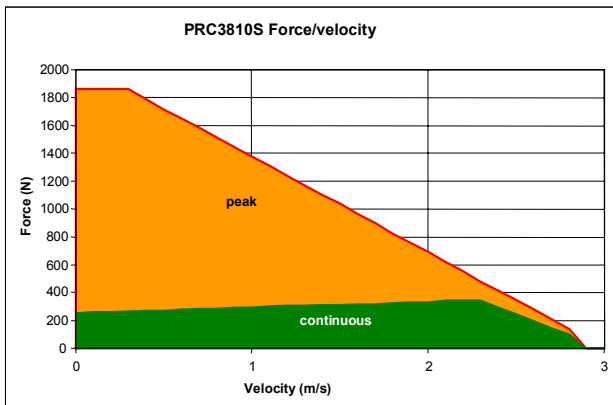
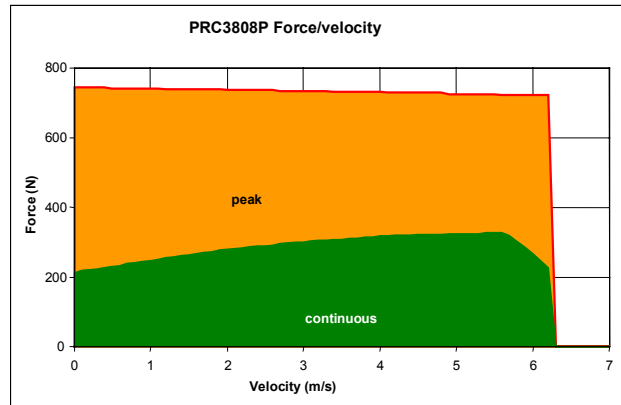
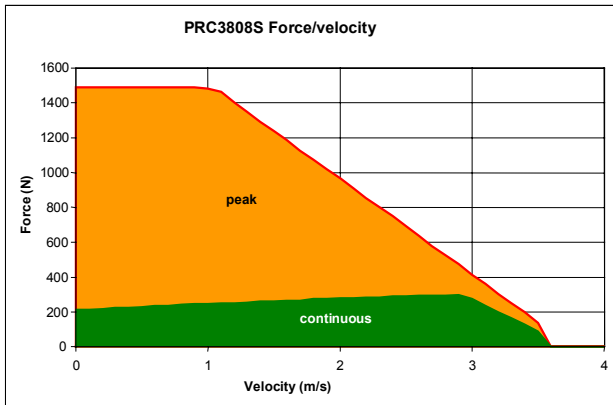
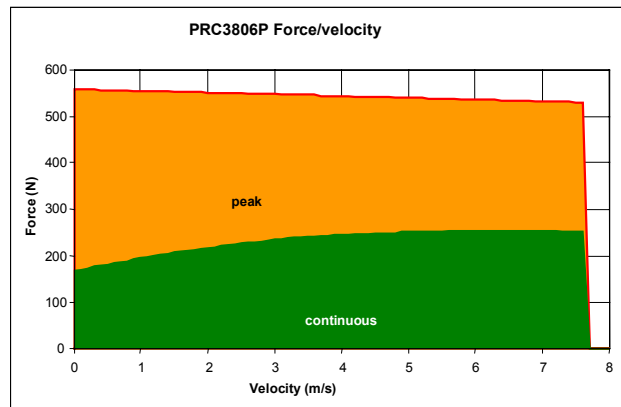
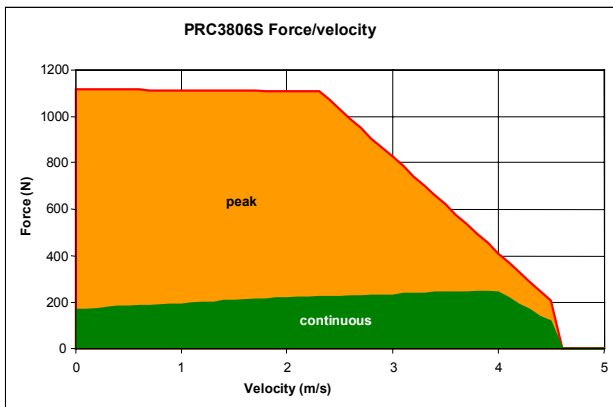
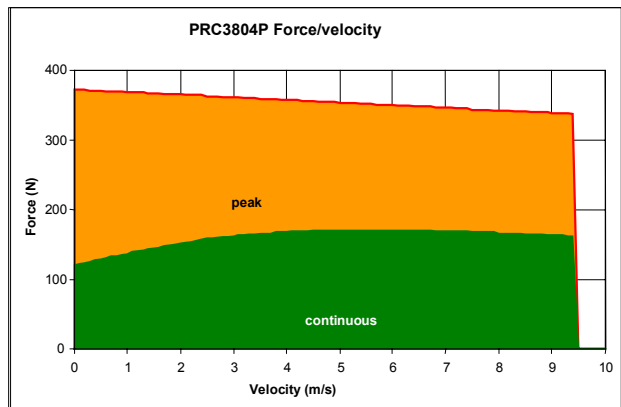
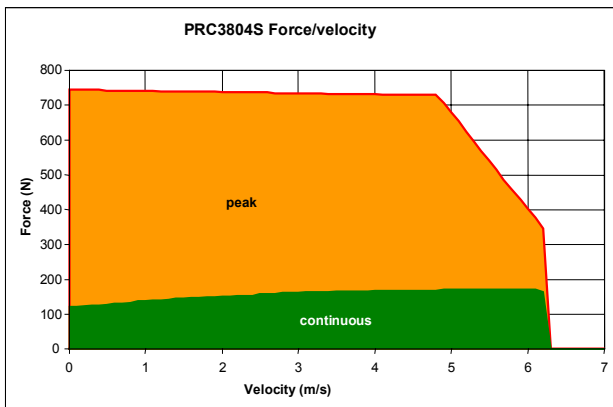



## Motor and feedback cable

The PowerRods have two hard-wired cables for motor power and position sensor. The standard cables for PRA and PRR supplied are flexible but are not suitable for continuous flex or energy chain applications. The cables for PRC are highly flexible as a standard.

### **Standard for PRA and PRR: Cable type S**

flexible cable	Power	Sensor
Overall diameter (nominal)	8.2mm	7.8mm
Outer jacket material	PVC	PVC
Number of conductors	4	4 x twisted pair
Size of conductors	1.5mm <sup>2</sup> (16 AWG)	0.14mm <sup>2</sup> (26 AWG)
Shielded/ unshielded	Shielded	Shielded
Operating voltage	600Vrms	300Vrms
Minimum bending radius-fixed routing	41mm	40mm
Operating temperature	-40°C to +90°C	-40°C to +70°C
UL certification	2586 105°C 600V	21083 90°C 300V

### **Standard for PRC and optionally available for PRA and PRR: Cable type R (=highly flexible)**

Suitable for continuous flex or energy chain applications.

highly flexible cable	Power	Sensor
Overall diameter (nominal)	7.6mm	7.8mm
Outer jacket material	PUR	PVC
Number of conductors	4	4 x twisted pair
Size of conductors	1.5mm <sup>2</sup> (16 AWG)	0.14mm <sup>2</sup> (26 AWG)
Shielded/ unshielded	Shielded	Shielded
Operating voltage	300Vrms	300Vrms
Minimum bending radius-fixed routing	38mm	58mm
Operating temperature	-40°C to +80°C	+5°C to +70°C
UL certification	20233 80°C 300V	21083 90°C 300V

max. cable length: 20m

## Ambient conditions

The PowerRod is intended for use in an environment within the following conditions:

Operating temperature	0 to +40°C
Storage temperature	-25 to +70°C
Altitude (above mean sea level)	1,000m
Overvoltage category	II (DIN VDE 0110)
Degree of contamination	2 (DIN VDE 0110)
EMC	light industry (EN61000-6-3 / EN61000-6-1)
Protection class	IP67

## Temperature sensor



It is strongly recommended that the motor over-temperature sensor is connected to the drive amplifier or servo controller at all times in order to reduce the risk of damage to the motor due to excessive temperatures.

Protection is provided by three, positive temperature coefficient (PTC) thermistors embedded in the motor phases. As the motor phase temperature approaches 100°C, the PTC thermistors exhibit a sharp increase in electrical resistance. This change in resistance can be detected by circuitry within the drive amplifier or servo controller and used to reduce or disable the output of the drive amplifier in order to protect the motor.

	Value	Unit
Resistance in the temperature range -20°C to +70°C	60 to 750	Ohm
Resistance at 85°C	≤1650	Ohm
Resistance at 95°C	≥3990	Ohm
Resistance at 105°C	≥12000	Ohm
Maximum continuous voltage	30	V d.c.

## Position sensor

The position sensor outputs analog, differential sine and cosine signals for providing position feedback. Shown below are the relationships between motor phase back EMF and position sensor outputs for one direction of motion (as shown by arrows). It should be noted that +SIN or -SIN is always in phase with motor phase U. For the motion shown, -SIN is in phase with motor phase U. For motion in the opposing direction +SIN is in phase with motor phase U.

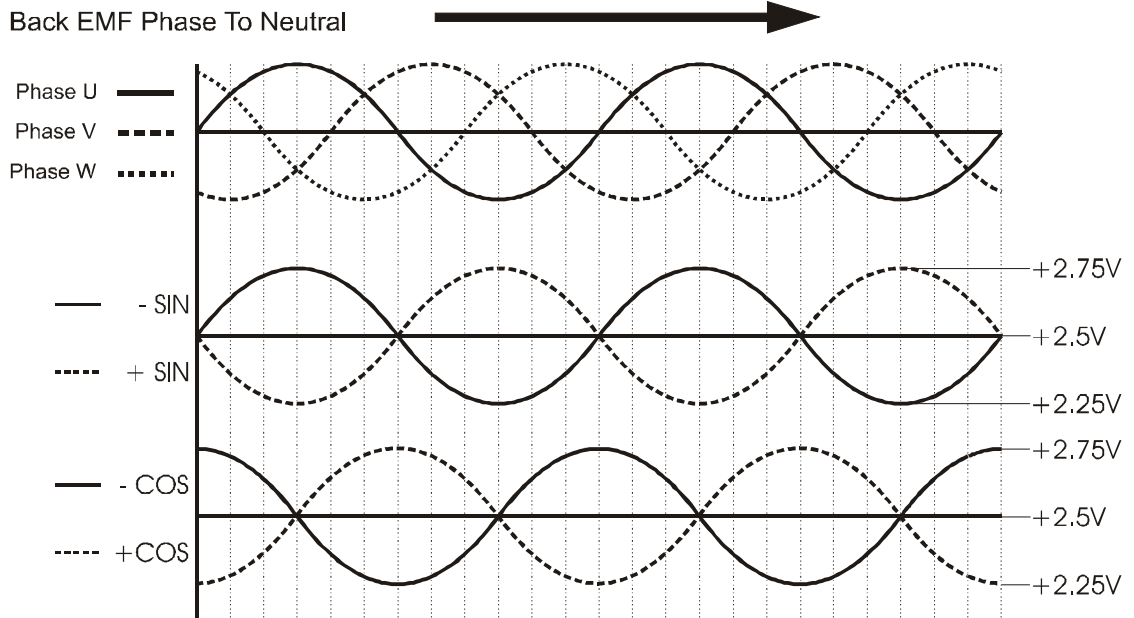

\*Positive movement direction with Compax3 Motormanager

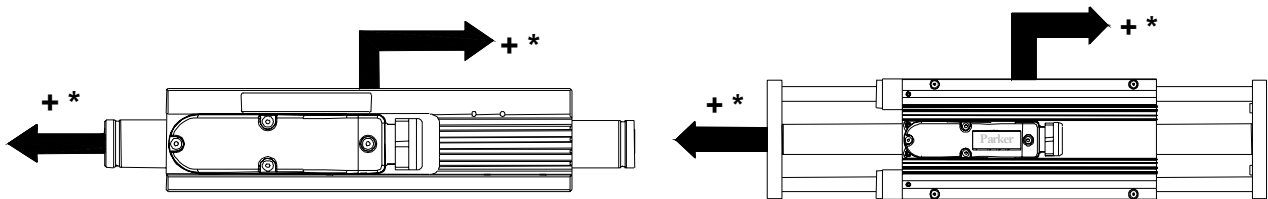

	PRA / PRC25	PRR25	PRA / PRC38	Unit
<b>Pole pitch</b>	51.2	51.2	71.2	mm
<b>Output current</b>	±10	±10	±10	mA
<b>Supply voltage</b>	5 ± 0.25	5 ± 0.25	5 ± 0.25	V d.c.
<b>Supply current (output current =0)</b>	15 ± 5	15 ± 5	15 ± 5	mA
<b>Repeatability (2) up to</b>	±20	±20	±40	µm

(2) With Compax3 servo controller Under constant operating conditions. Self-heating of the thrust rod by the motor will cause expansion in the thrust rod during the initial warm up period. In high duty applications (corresponding to an internal motor temperature of 80°C) a 1 metre thrust rod will expand typically by 250µm.

### Important!

*Please use for the parts marked grey with respect to the primary element, for the attachment and connection parts only non-iron materials. Use aluminium, stainless steel or plastic for example.*

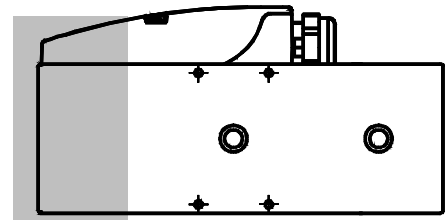
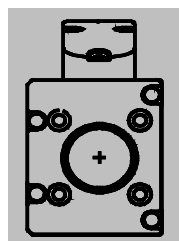

## Accessories

### In this chapter you can read about:

Nuts .....25  
 Terminal block TRS for the magnet rod TRC.....25

### Nuts

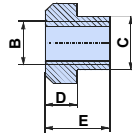
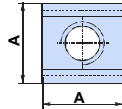
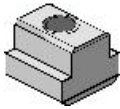

PRx	Order No.:	A	B	C	D	E
025	135-725390	10	M5	6	4	8
038	135-725400	13	M6	8	6	10

Nuts according to Din508 stainless

### Terminal block TRS for the magnet rod TRC

The terminal block is used for fixing the magnet rod (TRC).

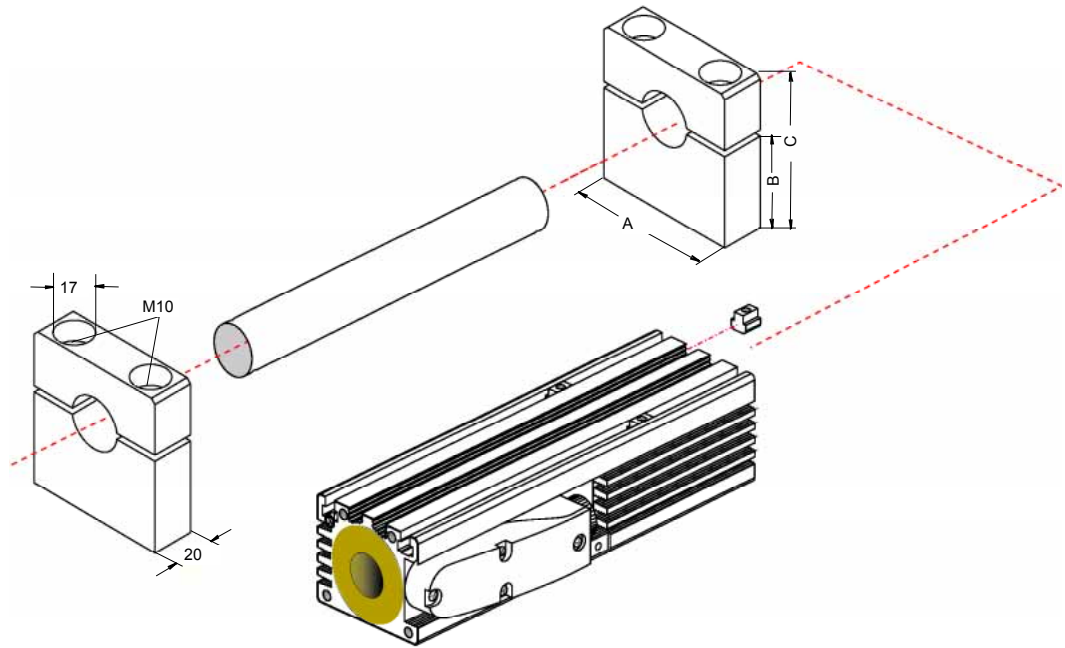

	A	B	C
TRS25 for TRC25	64	45	74.5
TRS38 for TRC38	85	54	90.5

**Note:** Primary element and magnet rod must be aligned with the aid of a guiding element to be provided by the customer.

## Order code

### Order code PRC

#### PRC forcer

Example

PRC	25	04	S	-	S	-	R	03	P
-----	----	----	---	---	---	---	---	----	---

Model /size: 25, 38

Forcer 04, 06, 08, 10

Winding

S: serial, P: Parallel

Environment:

S: standard, F: Food

Connection Type:

S: flexible, R: highly flexible

Cable length:

03: 3m, 05: 5m

Cable connection:

F: with flying leads,  
 P: for Compax3

#### Magnet rod TRC for PRC

Example

TRC25	-	0226
TRC25	-	xxxx

TRC25 for PRC25

xxxx: Length of thrust rod in mm

#### Possible lengths of the magnet rod TRC25 for PRC25 (in mm)

0226	0354	0482	0611	0739	0918	1175
0252	0380	0508	0636	0765	0970	1226
0277	0405	0534	0662	0790	1021	1278
0303	0431	0559	0688	0816	1072	1329
0329	0457	0585	0713	0867	1124	1380

Example

TRC38	-	0265
TRC38	-	xxxx

TRC38 for PRC38

xxxx: Length of thrust rod in mm

#### Possible lengths of the magnet rod TRC38 for PRC38 (in mm)

0265	0444	0622	0800	0978	1157	1335	1513
0301	0479	0657	0836	1014	1192	1370	1549
0337	0515	0693	0871	1050	1228	1406	1584
0372	0550	0729	0907	1085	1263	1442	1620
0408	0586	0764	0943	1121	1299	1477	

**Order code PRA**

Example	PRA	25	04	S	-	027	-	S	-	S	-	03	P
Model /size:	25, 38												
Forcer	04, 06, 08, 10												
Winding	S: serial, P: Parallel												
Stroke in mm:	PRA25: 027, 053, 078, 104, 130, 155, 181, 206, 232, 258, 283, 309 PRA38: 033, 069, 104, 140, 176, 211, 247, 282, 318												
Environment:	S: standard, F: Food												
Connection Type:	S: flexible, R: highly flexible												
Cable length:	03: 3m, 05: 5m												
Cable connection:	F: with flying leads, P: for Compax3												

**Order code for PRR**

Example	PRR	25	04	S	-	028	B	-	S	-	S	-	03	P
Model /size:	25													
Forcer	04, 06, 08, 10													
Winding	S: serial, P: Parallel													
Stroke in mm:	028, 054, 079, 105, 131, 156, 182, 207, 233, 259, 284, 310													
Guiding bushings:	B- ball bushings P-polymer sliding bushings													
Environment:	S: standard, F: Food													
Connection Type:	S: flexible, R: highly flexible													
Cable length:	03: 3m, 05: 5m													
Cable connection:	F: with flying leads, P: for Compax3													



# - Your partner for automation

Would you like more information?  
We would be happy to send you our brochures and catalogs!  
Or call us and set up a meeting.

## Our product program:

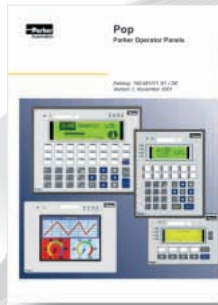

Visualisation



Distributed Automation



Control Technology



Drive Technology  
Servo Drives / Stepper Drives



Motors / Gears



Direct Drive Technology  
Linear motors / Torque motors



Handling Actuators  
Cylinders / Actuators



Precision Actuators  
Screw Driven / Linear Motor Driven



Parker  
Electromechanical Automation

We reserve the right to make technical changes.  
The information contained in this manual corresponds to the current status at the time of printing.



**Parker Hannifin GmbH & Co.KG**  
Electromechanical Automation  
Robert-Bosch-Str. 22  
D-77656 Offenburg,  
Germany  
☎ +49 (0)781 509 0  
☎ +49 (0)781 509 98176  
Website: [www.parker-eme.com](http://www.parker-eme.com)  
e-mail: [sales.hauser@parker.com](mailto:sales.hauser@parker.com)

**Parker Hannifin S. p. A**  
Electromechanical Automation  
Via Gounod 1  
I-20092 Cinisello Balsamo (MI),  
Italy  
☎ +39 0266012459  
☎ +39 0266012808  
Website: [www.parker-eme.com](http://www.parker-eme.com)  
e-mail: [sales.sbc@parker.com](mailto:sales.sbc@parker.com)

**Parker Hannifin plc**  
Electromechanical Automation  
Arena Business Centre  
Holy Rood Close, Poole, Dorset.  
BH17 7BA UK  
☎ +44 (0)1202 606300  
☎ +44 (0)1202 606301  
Website: [www.parker-eme.com](http://www.parker-eme.com)  
e-mail: [sales.digiplan@parker.com](mailto:sales.digiplan@parker.com)