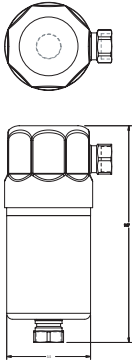
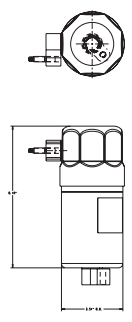
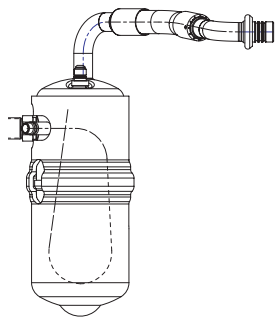
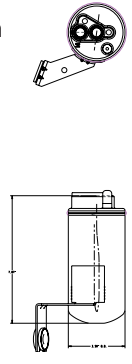
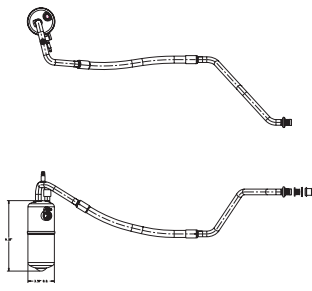
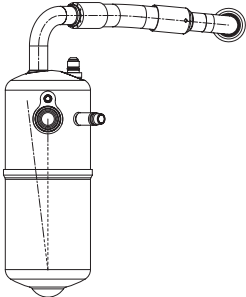
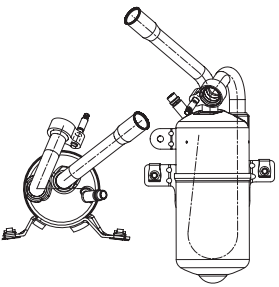
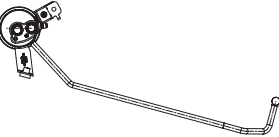

Table of Contents

Accumulators	Aluminum	A-1
	Steel	A-4
Receiver Dryers	Aluminum	D-1
	Steel Automotive Dryer Features	D-12
	Steel Receiver Dryers	D-13
Expansion Valves	Automotive Expansion Valve Features	T-2
	Bulb Type	T-3
	Equalizer Tube Fittings	T-3
	Right Angle Expansion Valves	T-4
	Bulbless or Block Valves	T-11
Miscellaneous	Low pressure cut-out switches	M-1
	Relief Valves	M-1
	Clutch Cycling Switch	M-1
	Female Quick Disconnect Fitting	M-1
Hose	Futura	H-1
	Guardian Barrier	H-2
Terms/Offer of Sale		TC-1
How to Place an Order		TC-3

Aluminum Accumulators

Illustration	Description	OEM No.	Application
<p>700001-s</p> 	<ul style="list-style-type: none"> • 3.5" diameter • 9.07" length • 1-1/16" -16" female o-rings (2) 	18-03837	Peterbilt Class 8
<p>700075-s</p> 	<ul style="list-style-type: none"> • 3.5" diameter • 9.07" length • 3/4" female peanut fitting inlet • 3/4" female peanut fitting outlet • mounting studs 	18-04171	Peterbilt Class 8
<p>700038-am</p> 	<ul style="list-style-type: none"> • 3.5" diameter • 9.31" length • 5/8" male o-ring • 3/4" male SLC • 134a charge port • M12 switch port 	F75Z 19C836 BA	96-97 Ford F-150
<p>700124-am</p> 	<ul style="list-style-type: none"> • 3.5" diameter • 7.87" length • Pad mount • M12 switch port • Bracket with isolator • Switch 	05058013AA	00-01 PT Crusier

Aluminum Accumulators

Illustration	Description	OEM No.	Application
<p>700142-am</p> 	<ul style="list-style-type: none"> • 3.5" diameter • 9.32" length • 3/4" female peanut • 3/4" female spring lock • M12 switch port • 134a charge port • Switch installed 	<p>YL 3Z 19C836 AA</p>	<p>00-06 Ford F-150 4.2L</p>
<p>700180-am</p> 	<ul style="list-style-type: none"> • 3.5" diameter • 9.32" length • 3/4" female peanut • 3/4" male SLC • M12 switch port, 134a charge port • Bracket • Switch installed 	<p>F85Z 19C836 AB</p>	<p>98-03 Ford F-150</p>
<p>700183-am</p> 	<ul style="list-style-type: none"> • 3.5" diameter • 8.3" length • 3/4" female spring lock • 3/4" female peanut • 134a charge port • Bracket 	<p>6S4Z 19C836 A</p>	<p>00-07 Ford Focus</p>
<p>700200-am</p> 	<ul style="list-style-type: none"> • 3.5" diameter • 9.97" length • Pad mount inlet • Pad mount outlet • 134a charge port • Bracket • Mounting studs 	<p>1L2Z 19C836 AA</p>	<p>2001 Ford Explorer</p>

Aluminum Accumulators

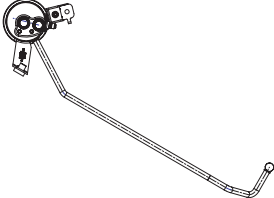
Illustration	Description	OEM No.	Application
700210-am 	<ul style="list-style-type: none"> • 3.5" diameter • 9.97" length • Pad mount inlet • Pad mount outlet • 134a charge port • Bracket, mounting studs 	1L2Z 19C836 BA	00-05 Ford Explorer
700220-am 	<ul style="list-style-type: none"> • 3.5" diameter • 9.87" length • Pad mount inlet • Pad mount outlet • M12 switch port • Bracket, M8 mounting stud • 1/2 charge line 	6L2Z 19C836 A	06 Ford Explorer

Steel Accumulators

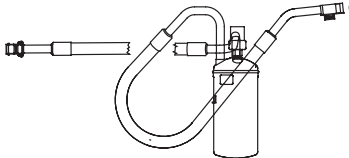
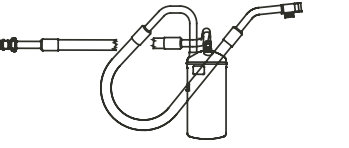
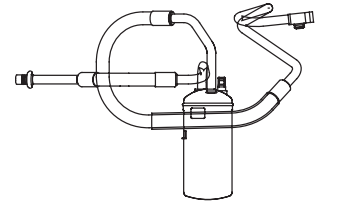
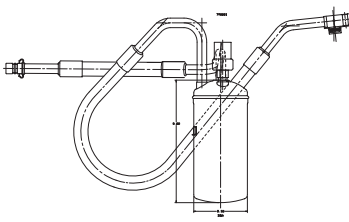
Illustration	Description	OEM No.	Application
<p>637958</p> 	<ul style="list-style-type: none"> • 3.5" diameter • 11.8" length • 5/8" male spring lock fitting • 5/8" male peanut • M12 male switch port • Switch installed 	55036152	Chrysler 92-94 92-94 Grand Cherokee 4L
<p>638113</p> 	<ul style="list-style-type: none"> • 3.5" diameter • 11.8" length • 5/8" male spring lock fitting • 5/8" male peanut • M12 male switch port • Switch installed 	04740773	Chrysler 91-96 Grand Cherokee 4.0L
<p>737754</p> 	<ul style="list-style-type: none"> • 3.5" diameter • 12.7" length • 5/8" male spring lock fitting • 5/8" Male Peanut • M12 Male Switch port • No switch installed 	04740767	Chrysler 92-96 Cherokee 5.2L
<p>792001</p> 	<ul style="list-style-type: none"> • 3.5" diameter • 11.8" length • 5/8" male spring lock fitting • 5/8" male peanut • M12 male switch port • Switch installed 	55116120	97 Grand Cherokee 4.0L

Steel Accumulators

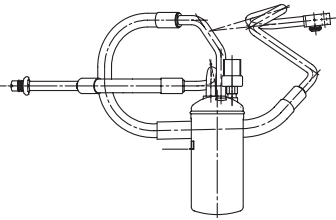
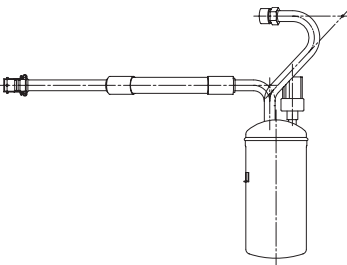
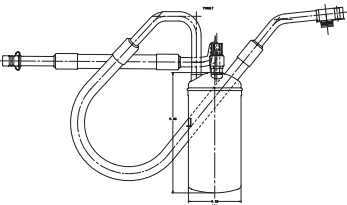
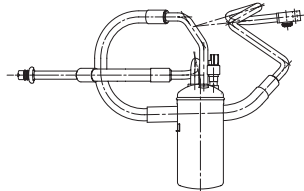
Illustration	Description	OEM No.	Application
<p>792002</p> 	<ul style="list-style-type: none"> • 3.5" diameter • 12.7" length • 5/8" male spring lock fitting • 5/8" male peanut • M12 male switch port • Switch installed 	55116121	97 Grand Cherokee 5.2L
<p>792003</p> 	<ul style="list-style-type: none"> • 3.5" diameter • 13.9" length • 5/8" male spring lock fitting • 7/8" male o-ring • M12 male switch port • Switch installed 	55116122	Grand Cherokee Diesel
<p>792017</p> 	<ul style="list-style-type: none"> • 3.5" diameter • 11.8" length • 5/8" male spring lock fitting • 5/8" male peanut • M12 male switch port • Switch installed 	55116191	98 Grand Cherokee 4.0L
<p>792018</p> 	<ul style="list-style-type: none"> • 3.5" diameter • 12.7" length • 5/8" male spring lock fitting • 5/8" male o-ring • M12 male switch port • Switch installed 	55116192	98 Grand Cherokee 4.0L

Steel Accumulators

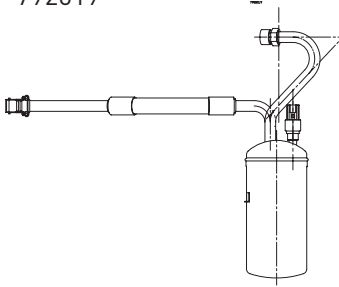
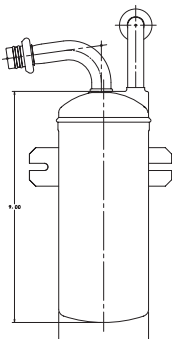
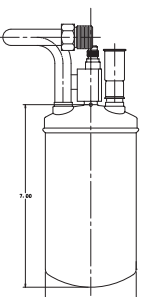
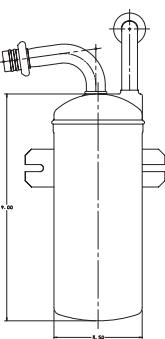
Illustration	Description	OEM No.	Application
<p>792019</p> 	<ul style="list-style-type: none"> • 3.5" diameter • 13.9" length • 5/8" male spring lock • 7/8" male o-ring • M12 male switch port • Switch installed 	<p>55116193</p>	<p>98 Grand Cherokee Diesel</p>
<p>089092-00</p> 	<ul style="list-style-type: none"> • 3.5" diameter • 11.58" length • 3/4" male spring lock • 5/8" male spring lock • 7/16" male switch port • Switch not installed, bracket 	<p>E8UZ 19C836A (without switch)</p>	<p>Ford Econoline Motorcraft YF 1494</p>
<p>089107-00</p> 	<ul style="list-style-type: none"> • 3.5" diameter • 9.59" length • 7/8" male o-ring • 5/8" female spring lock • 7/16" male switch port • 7/16" R12 charge port 	<p>E4TZ 19C836 B</p>	<p>Ford Ranger Motorcraft YF 1852</p>
<p>089108-00</p> 	<ul style="list-style-type: none"> • 3.5" diameter • 11.58" length • 3/4" male spring lock • 5/8" male spring lock • 7/16" male switch port • Switch installed, bracket 	<p>E8UZ 19C836A (with switch)</p>	<p>Ford Econoline Motorcraft YF 1494</p>

Steel Accumulator Charts

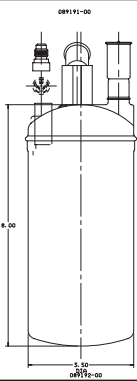
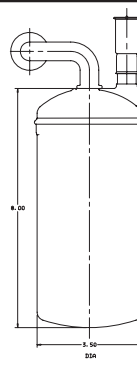
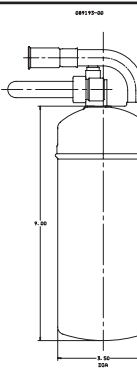
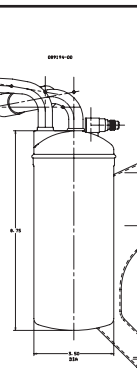
Illustration	Description	OEM No.	Application
089191-00 	<ul style="list-style-type: none"> • 3.5" diameter • 10.0" length • 5/8" female spring lock • 5/8" female spring lock • 7/16" male switch port • 7/16" R12 charge port 	F2HZ 19C836 C	Ford Heavy Truck YF 1726
089192-00 	<ul style="list-style-type: none"> • 3.5" diameter • 10.4" length • 5/8" male spring lock • 5/8" female spring lock • 7/16" male switch port 	F2CH 19C808 AA	92-94 Ford Escort YF 1789
089193-00 	<ul style="list-style-type: none"> • 3.5" diameter • 10.8" length • 7/8" male o-ring • 5/8" female spring lock • 7/16" male switch port • 7/16" R12 charge port 	F1TZ 19C836B	Ford Explorer YF1770
089194-00 	<ul style="list-style-type: none"> • 3.5" diameter • 10.8" length • 5/8" male spring lock • 5/8" male spring lock • 7/16" male switch port • Bracket 	F2UZ 19C836 A	Ford Econoline Motorcraft YF 1747

Steel Accumulators

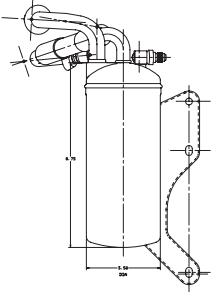
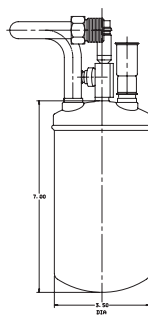
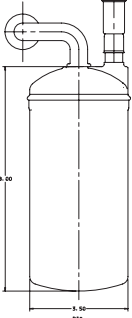
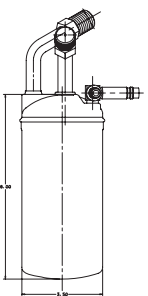
Illustration	Description	OEM No.	Application
<p>089245-00</p> 	<ul style="list-style-type: none"> • 3.5" diameter • 10.8" length • 5/8" male spring lock • 3/4" male spring lock • M12 male switch port • 134a charge port • Bracket 	<p>F4UZ 19C836 A</p>	<p>Ford Econoline Motorcraft YF 2013</p>
<p>089246-00</p> 	<ul style="list-style-type: none"> • 3.5" diameter • 9.6" length • 7/8" male o-ring • 5/8" female spring lock • M12 male switch port • 134a charge port 	<p>F4TZ 19C836 C</p>	<p>Ford Ranger Motorcraft YF 2152</p>
<p>089247-00</p> 	<ul style="list-style-type: none"> • 3.5" diameter • 9.2" length • 5/8" male spring lock • 5/8" female spring lock • M12 male switch port 	<p>F5CH 19C808 AA</p>	<p>95- Ford Escort</p>
<p>089248-00</p> 	<ul style="list-style-type: none"> • 3.5" diameter • 12.3" length • 7/8" male o-ring • 7/8" male o-ring • M12 male switch port • 134a charge port 	<p>F4HZ 19C836 A</p>	<p>Ford Heavy Truck YF 2159</p>

Steel Accumulators

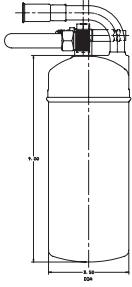
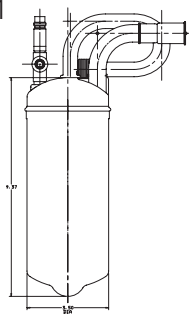
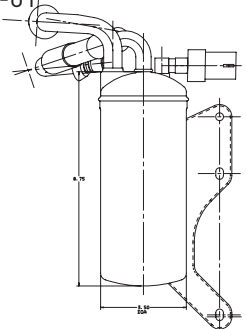
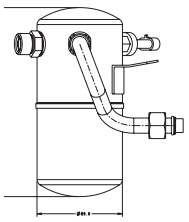
Illustration	Description	OEM No.	Application
089249-00 	<ul style="list-style-type: none"> • 3.5" diameter • 10.8" length • 7/8" male o-ring • 5/8" female spring lock • 134a charge port 	F4TZ 19C836 B	Ford Explorer YF 2151
089265-01 	<ul style="list-style-type: none"> • 3.5" diameter • 11.8" length • 7/8" male o-ring • 3/4" female spring lock • M12 Male Switch Port • 134a Charge Port 	F5TZ 19C 836 A	Ford Explorer YF 2203
089268-01 	<ul style="list-style-type: none"> • 3.5" diameter • 10.8" length • 5/8" spring lock • 3/4" male spring lock • M12 male switch port • 134a charge port • Switch 	F6UZ 19C836 AA	Ford Econoline
089274-01 	<ul style="list-style-type: none"> • 89 mm diameter • 197 mm length • M22 male o-ring • M22 female swivel • M12 male switch port • 134a charge port • Switch • Bracket 	GD7A615A0	Mazda 626

Steel Accumulators

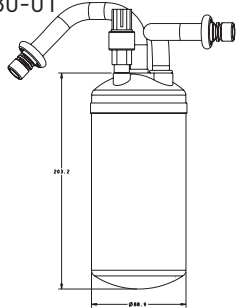
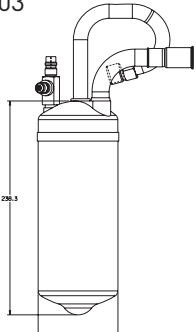
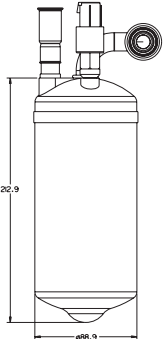
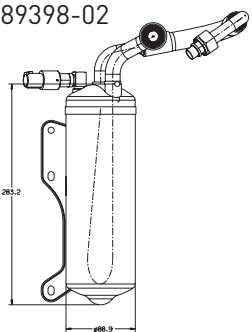
Illustration	Description	OEM No.	Application
<p>089280-01</p> 	<ul style="list-style-type: none"> • 3.5" diameter • 10.3" length • 5/8" male spring lock • 5/8" male spring lock • M12 male switch port • Pressure switch installed 	55055838AE	1998 - Dodge Ram 2001 Truck
<p>089308-03</p> 	<ul style="list-style-type: none"> • 3.5" diameter • 11.6" length • 7/8" male o-ring • 3/4" female spring lock • 134a charge port • M12 male switch port 	F87Z 19C836 AA	Ford Explorer YF 2478
<p>089309-04</p> 	<ul style="list-style-type: none"> • 3.5" diameter • 9.6" length • 5/8" male spring lock • 5/8" female spring lock • M12 male switch port • Switch installed 	XS4Z 19C836 AA	Ford Escort YF 2339
<p>089398-02</p> 	<ul style="list-style-type: none"> • 3.5" diameter • 11.1" length • 7/8" female swivel nut • 3/4" male spring lock • M12 male switch port • Switch installed, bracket 	2C2Z 19C836 BA	Ford Econoline Aux YF 2832

Steel Accumulator Charts

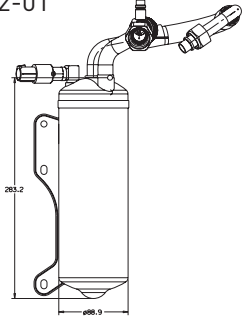
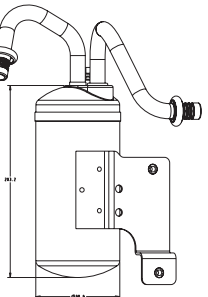
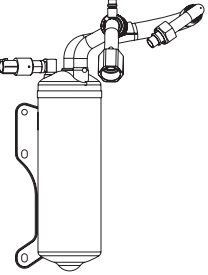
Illustration	Description	OEM No.	Application
<p>089412-01</p> 	<ul style="list-style-type: none"> • 3.5" diameter • 11.1" length • 7/8" female swivel nut • 3/4" rigid female o-ring • M12 male switch port • Switch, 134a charge port, bracket 	4C2Z 19C836 AA	Ford Econoline Diesel YF 2946
<p>089478-01</p> 	<ul style="list-style-type: none"> • 3.5" diameter • 10.4" length • 5/8" male spring lock • 5/8" male spring lock • 134a charge port • Bracket w/ mounting bolts 	55057016AA	2000- Dodge Ram
<p>089504-02</p> 	<ul style="list-style-type: none"> • 3.5" diameter • 11.1" length • 7/8" female swivel nut • 3/4" rigid female o-ring • M12 male switch port • Switch, 134a charge port, bracket 	5C2Z 19C836 AA	Ford Econoline Front only YF 3118

Aluminum Receiver Dryers

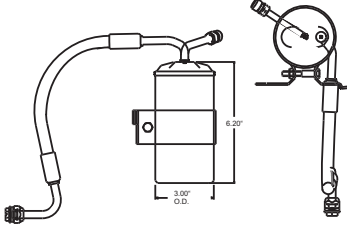
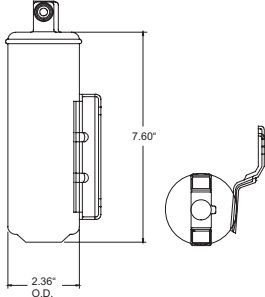
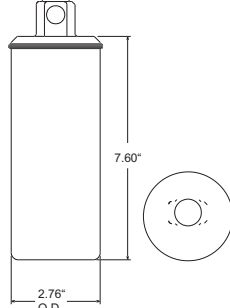
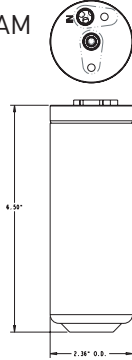
Illustration	Description	OEM No.	Application
<p>248751</p> 	<ul style="list-style-type: none"> • 3.00" diameter • 6.2" length • 9/16" - 18" UNF-2A male fitting outlet • 5/8" - 18" UNF-2B female fitting inlet • Bracket 	21030794	Saturn 92-93 Saturn Models
<p>248754</p> 	<ul style="list-style-type: none"> • 2.36" diameter • 7.6" length • 5/8" - 18" UNF-2A outlet • 5/16" - 18" UNF-2A inlet • Bracket 	LB50-61-500	Mazda 94-95 MPV
<p>248768</p> 	<ul style="list-style-type: none"> • 2.76" diameter • 7.6" length • M16 x 1.5.-6G inlet & outlet fittings 	NA01-61-500	Mazda 89-94 Miata
<p>800333-AM</p> 	<ul style="list-style-type: none"> • 2.36" diameter • 6.5" length • Pad mount inlet & outlet 	80351-ST7-A113	Honda 94-97 Del Sol 94-2001 Integra 91-95 Civic

Aluminum Receiver Dryers

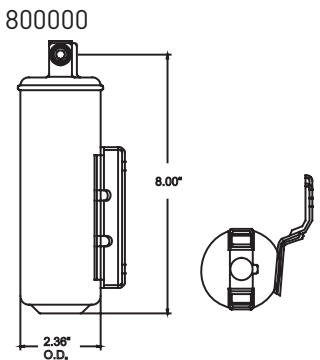
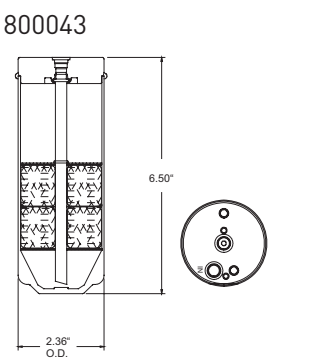
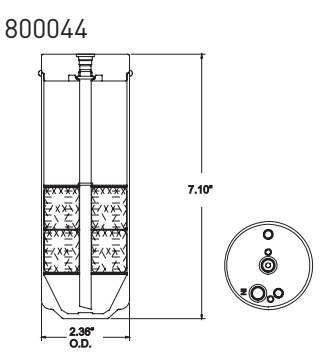
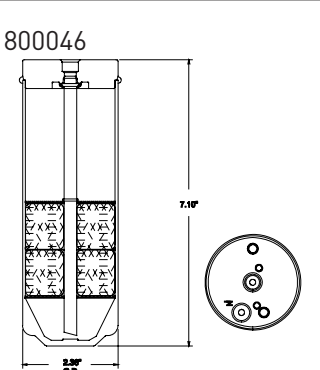
Illustration	Description	OEM No.	Application
<p>800000</p> 	<ul style="list-style-type: none"> • 2.36" diameter • 8.00" length • M16 x 1.5-6G inlet & outlet • Bracket 	<p>NA75-61-500</p>	<p>Mazda 95-96 Miata</p>
<p>800043</p> 	<ul style="list-style-type: none"> • 2.36" diameter • 6.50" length • M6 x 1.0 bolt holes • Inlet & outlet pad mounts w/ M6 mounting hole • Sight glass 	<p>88471-12020 88471-100030 94846222 MB439834 95330-60A50 95330-60B10 E9JY-19959-A MB439834 MB8994979</p>	<p>Toyota 87-91 Cary, Land Cruiser 88-93 Corolla 89-91 Cressida 89-92 Pickup, 4-Runner, Tercel 92 Paseo Geo 90-91 Tracker (Delco 15-1744) 90-92 Metro, Prizm Mitsubishi 90-93 Eclipse Suzuki 89-92 Sidekick 89-92 Swift Ford 90-93 Capri Chrysler 90-93 Laser 92 Colt, Summit</p>
<p>800044</p> 	<ul style="list-style-type: none"> • 2.36" diameter • 7.10" length • M6 x 1.0 bolt holes • Inlet & outlet pad mounts w/ M6 mounting hole • Sight glass 	<p>88471-16040 88471-50010 96059451 MB657527 AW331609</p>	<p>Toyota 89-9 4-Runner, Pickup 90-93 Celica, Land Cruiser 91-93 MR2, Tercel, paseo 92-93 Camry Lexus 92-94 ES300 92-93 SC300, SC400 91-92 LS400 Geo 89-93 Tracker (Delco 15-1731) Mitsubishi 92-93 Montero 93 Diamante Wagon</p>
<p>800046</p> 	<ul style="list-style-type: none"> • 2.36" diameter • 7.10" length • M6 x 1.0 bolt holes • Inlet & outlet pad mounts • R-134a 	<p>88471-02020 88471-06020 88471-20030 88471-20050 88471-28070 88471-34010 88471-50020 88471-60010 94855108 88470-33020 88470-20230 AW337382 MB918516 MR117107</p>	<p>Toyota 93-94 T-100 Pickup 94 Land Cruise, 4-runner 4WD 94 Camry, Celica, Corolla 94 Paseo, Previa 94 Supra, Tercel 94 MR2 Geo 94 Prizm (Delco 15-1734) Lexus 93-94 GS300, LS400 94 SC300, SC400 Mitsubishi 94 Diamante Wagon 94 Expo, Expo LRV 94 Montero</p>

Aluminum Receiver Dryers

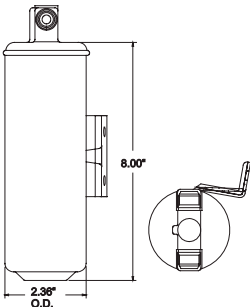
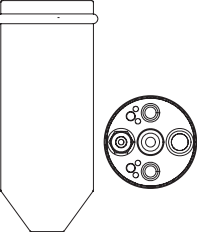
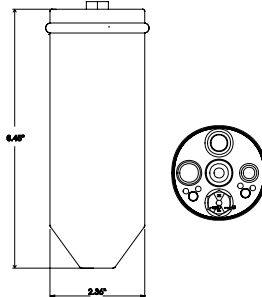
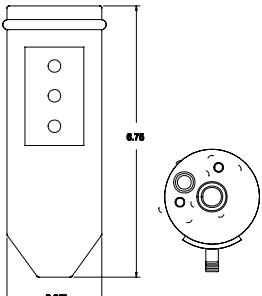
Illustration	Description	OEM No.	Application
<p>800059</p> 	<ul style="list-style-type: none"> • 2.36" diameter • 8" length • M16 x 1.5 inlet & outlet fittings • Bracket 	<p>LB90-61-500</p>	<p>Mazda 89-91 MPV</p>
<p>800108</p> 	<ul style="list-style-type: none"> • 2.36" diameter • 5.89" length • 3/8" - 24" UNF-2B switch port • Fuse plug • Sight glass 	<p>H261-61-501B 92131-53F00 9231-96E05 73030-AA061 73030-AA011</p>	<p>Mazda 96 929 Nissan 91-92 240SX 91-92 Maxima, Stanza Subaru 90-92 Legacy</p>
<p>800135</p> 	<ul style="list-style-type: none"> • 2.36" diameter • 6.45" length • Inlet & outlet pad mounts • Fuse plug • Sight glass • 3/8" - 24" UNF-2B switch port 	<p>92131-30R00 92131040F01 92131085E00</p>	<p>Nissan 90-92 Access 90 Stana 89-90 240SX 89-90 Maxima Infinity 91-92 M20 90 M30</p>
<p>800136</p> 	<ul style="list-style-type: none"> • 2.36" diameter • 6.75" length • M8 x 1.5 mounting stud bracket • Pad mount fittings 		<p>96-97 Caravan 96-97 Voyager</p>

Aluminum Receiver Dryers

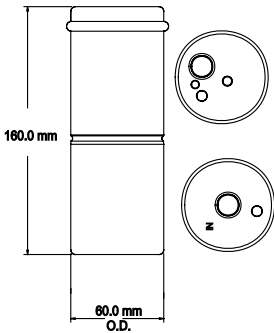
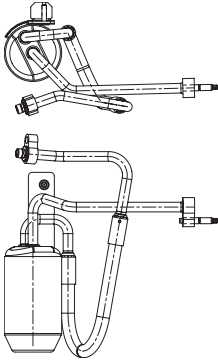
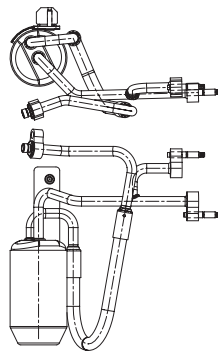
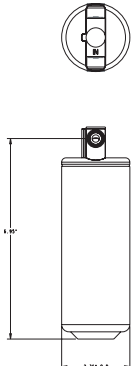
Illustration	Description	OEM No.	Application
<p>800177</p> 	<ul style="list-style-type: none"> • 60 mm diameter • 160 mm length • M8 x 1.25 top & bottom mounting ports 	<p>--</p>	<p><u>Volkswagen</u> 98-99 Beetle/Golf</p>
<p>800324</p> 	<ul style="list-style-type: none"> • 2.98" diameter • 11" length • 1/2" male peanut inlet fitting • 1/2" female peanut outlet fitting • Bracket 	<p>6L1Z 19959 AA</p>	<p><u>Ford</u> 2001-06 Expedition Navigator</p>
<p>800325</p> 	<ul style="list-style-type: none"> • 2.98" diameter • 11" length • 1/2" male peanut inlet fitting • 1/2" female peanut outlet fitting • 1/2" female auxiliary fitting • Bracket 	<p>6L1Z 19959 AA</p>	<p><u>Ford</u> 01-06 Expedition Navigator Aux.</p>
<p>800332-AM</p> 	<ul style="list-style-type: none"> • 2.36" diameter • 6.95" length • 5/8" male o-ring inlet & outlet fittings 	<p>80351-SV1-A110</p>	<p><u>Honda</u> 93-97 Accord</p>

Aluminum Receiver Dryers

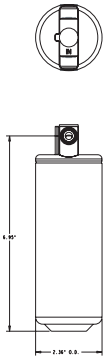
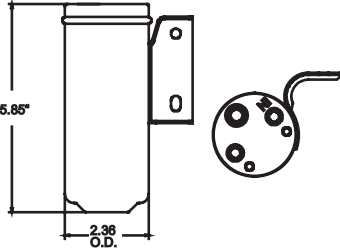
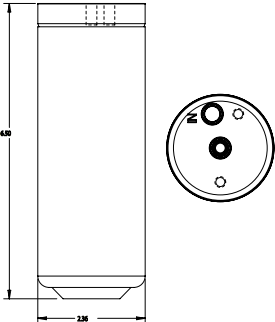
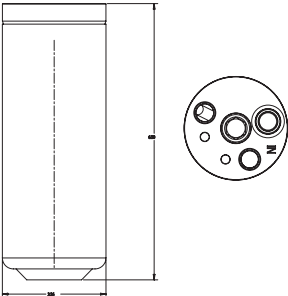
Illustration	Description	OEM No.	Application
<p>800334-AM</p> 	<ul style="list-style-type: none"> • 2.36" diameter • 6.95" length • Male o-ring inlet & outlet 	<p>80351-SV7-A110</p>	<p>Honda 2000 Integra</p>
<p>800012-S</p> 	<ul style="list-style-type: none"> • 2.36" diameter • 5.85" length • M6 x 1.0 bolt holes • Inlet & outlet pad mounts • 3/8" -24" UNF-2B switch port • Bracket 	<p>BC1M 61-500</p>	<p>Mazda 95-96 Protege</p>
<p>800337-AM</p> 	<ul style="list-style-type: none"> • 2.36" diameter • 6.5" length • Inlet & outlet pad mounts 	<p>80351-SR1-H110</p>	<p>Honda 92-94 Civic</p>
<p>800338-AM</p> 	<ul style="list-style-type: none"> • 2.36" diameter • 6.5" length • Inlet & outlet pad mounts • M11 female switch port • Sight glass 	<p>80351-SO1-A110</p>	<p>Honda 94-97 Accord</p>

Aluminum Receiver Dryers

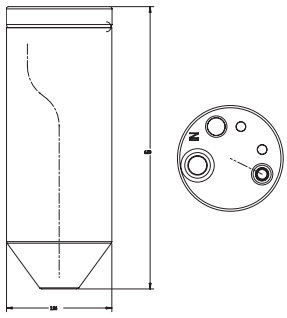
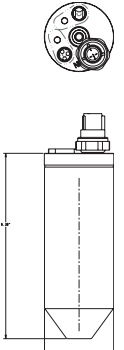
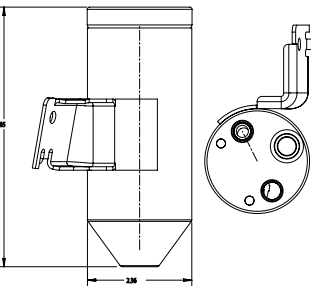
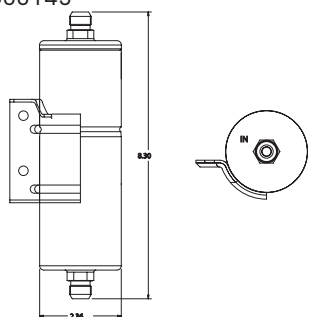
Illustration	Description	OEM No.	Application
<p>800090-AM</p> 	<ul style="list-style-type: none"> • 2.36" diameter • 6.3" length • 10mm pad mount inlet & outlet • M11 female switch port 	<p>80351-S84-A010</p>	<p>Honda 95-02 Accord</p>
<p>800092-AM</p> 	<ul style="list-style-type: none"> • 2.36" diameter • 6.3" length • 10 mm pad mount inlet & outlet • M11 female switch port • Dual pressure switch • Sight glass 	<p>80351-S84-E010</p>	<p>Honda 98-02 Accord</p>
<p>800144-s</p> 	<ul style="list-style-type: none"> • 2.36" diameter • 5.8" length • Pad mount inlet & outlet • M11 female switch port • Bracket • Sight glass 	<p>BJOE61501A</p>	<p>Mazda Protege</p>
<p>800145</p> 	<ul style="list-style-type: none"> • 2.36" diameter • 8.3" length • M16 male o-ring inlet • M16 male O-ring outlet • Bracket 	<p>NC1061500A</p>	<p>Mazda Miada</p>

Aluminum Receiver Dryers

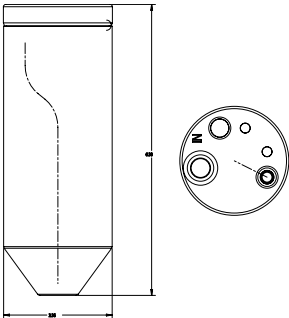
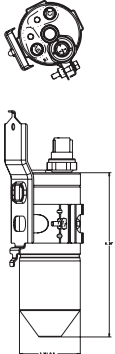
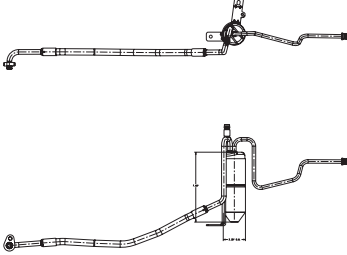
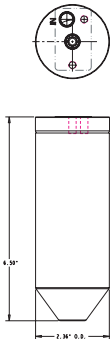
Illustration	Description	OEM No.	Application
<p>800190-AM</p> 	<ul style="list-style-type: none"> • 2.36" diameter • 6.3" length • 10 mm pad mount inlet • 10 mm pad mount outlet • M11 female switch port • Bracket • Pressure switch 	<p>80350-S5D-A011</p>	<p>Honda 01-05 Civic</p>
<p>800191-AM</p> 	<ul style="list-style-type: none"> • 2.36" diameter • 6.3" length • Pad mount inlet & outlet • M11 female switch port • Bracket • Pressure switch • Sight glass 	<p>80350-S5D-A111M1</p>	<p>Honda 01 Civic</p>
<p>800200-AM</p> 	<ul style="list-style-type: none"> • 2.36" diameter • 6.3" length • 1/2" axial male inlet fitting • Male peanut outlet fitting • 134a charge port • Bracket 	<p>55116560-AF</p>	<p>Chrysler 00-01 Jeep</p>
<p>800220-AM</p> 	<ul style="list-style-type: none"> • 2.36" diameter • 6.5" length • Pad mount inlet & outlet 	<p>24439251</p>	<p>Chrysler 99-03 Saturn LS</p>

Aluminum Receiver Dryers

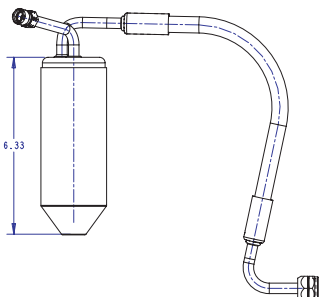
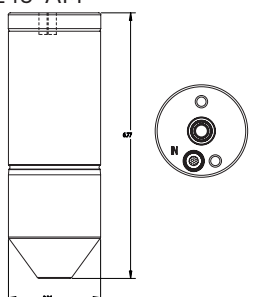
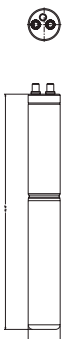
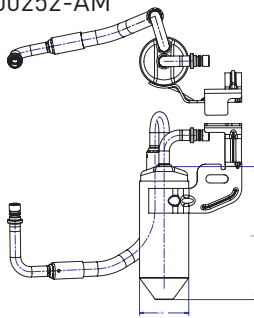
Illustration	Description	OEM No.	Application
<p>800221-AM</p> 	<ul style="list-style-type: none"> • 2.36" diameter • 6.35" length • Female swivel inlet • Male o-ring outlet • Bracket 	<p>21031426</p>	<p>Saturn 94-97 Saturn</p>
<p>800243-AM</p> 	<ul style="list-style-type: none"> • 2.36" diameter • 6.77" length • .52 female pad mount inlet • .69 female pad mount outlet • M6 mounting holes 	<p>323167</p>	<p>Chrysler 03-06 RS Minivan</p>
<p>800247-AM</p> 	<ul style="list-style-type: none"> • 1.38" diameter • 10.12" length • 19/64" pad mount inlet & outlet • M6 mounting holes 	<p>80351-SDA-A01</p>	<p>Honda 03-07 Accord</p>
<p>800252-AM</p> 	<ul style="list-style-type: none"> • 2.36" diameter • 6.35" length • 1/2" male dual o-ring inlet & outlet • Bracket 	<p>10333862 52403512</p>	<p>GM 03-05 Regal 03-05 Grand Prix 03-05 Lumina 03-05 Monte Carlo</p>

Aluminum Receiver Dryers

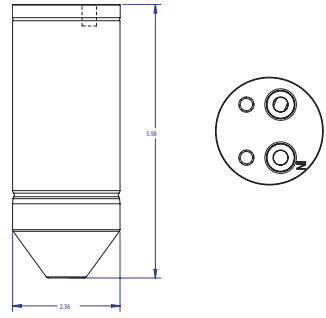
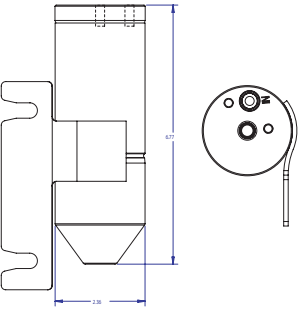
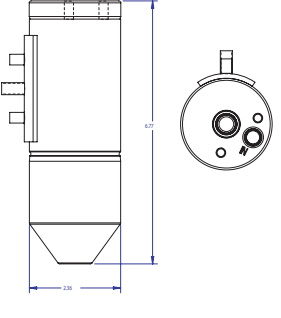
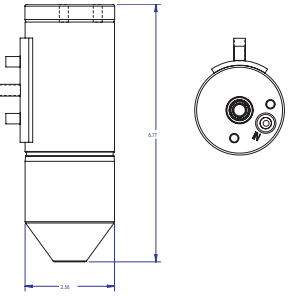
Illustration	Description	OEM No.	Application
<p>800258-AM</p> 	<ul style="list-style-type: none"> • 2.36" diameter • 5.98" length • .61 female pad mount inlet & outlet • M8 mounting holes 	--	Chrysler 03-05 B-Van
<p>800267-AM</p> 	<ul style="list-style-type: none"> • 2.36" diameter • 6.77" length • .52 female pad mount inlet • .401 female pad mount outlet • M6 mounting holes • Bracket 	323129	Chrysler 04 Pacifica
<p>800276-AM</p> 	<ul style="list-style-type: none"> • 2.36" diameter • 6.77" length • .436 female pad mount inlet • .696 female pad mount outlet • M6 mounting holes • Bracket 	04682592AB	Chrysler 96-00 Minivan
<p>800278-AM</p> 	<ul style="list-style-type: none"> • 2.36" diameter • 6.77" length • .436 female pad mount inlet • .696 female pad mount outlet • M6 mounting holes • Bracket 	04682623AB	Chrysler 96-00 Minivan

Aluminum Receiver Dryers

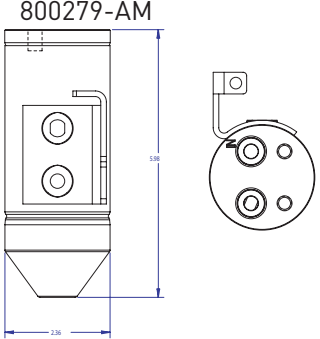
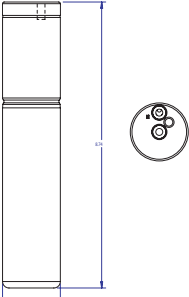
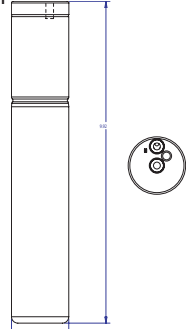
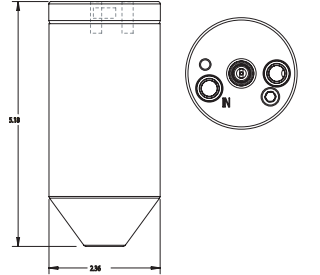
Illustration	Description	OEM No.	Application
<p>800279-AM</p> 	<ul style="list-style-type: none"> • 2.36" diameter • 5.98" length • .613 female pad mount & outlet • M8 mounting holes • Bracket 	<p>05003270AB</p>	<p>Chrysler 98-99 B-Van</p>
<p>800280-AM</p> 	<ul style="list-style-type: none"> • 1.77" diameter • 8.77" length • .401 female pad mount & outlet • M6 mounting holes • Bracket 	<p>--</p>	<p>03-06 Montero Sport</p>
<p>800290-AM</p> 	<ul style="list-style-type: none"> • 1.77" diameter • 9.92" length • .401 female pad mount & outlet • M6 mounting holes • Bracket 	<p>--</p>	<p>GM 04-06 Aztec Rendevous</p>
<p>800295-AM</p> 	<ul style="list-style-type: none"> • 2.36" diameter • 6.8" length • Pad mount inlet & outlet • 134a charge port • Mounting studs 	<p>04883282</p>	<p>Chrysler 97-99 Neon</p>

Aluminum Receiver Dryers

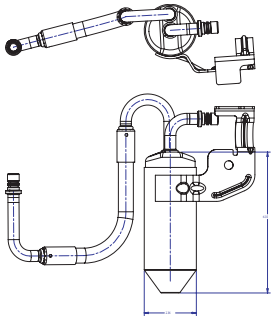
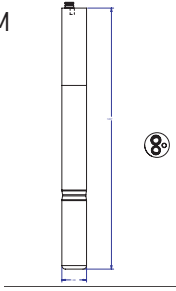
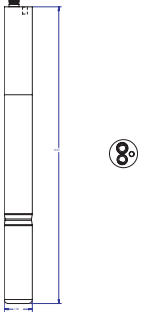
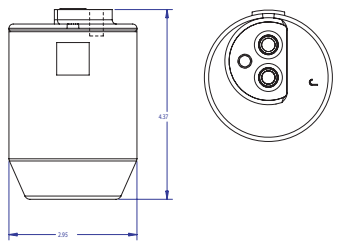
Illustration	Description	OEM No.	Application
	<ul style="list-style-type: none"> • 2.36" diameter • 6.35" length • 1/2 in. male dual o-ring inlet & outlet • Bracket 	<p>10344418 / 52404617</p>	<p>Chevrolet 02-05 Impala</p>
	<ul style="list-style-type: none"> • 1.38" diameter • 14.57" length • .482 male o-ring inlet • .485 female o-ring outlet • Bracket • M6 mounting bolt hole 	<p>--</p>	<p>05 Hummer 3</p>
	<ul style="list-style-type: none"> • 1.38" diameter • 14.57" length • .482 Male o-ring inlet • .485 female o-ring outlet • Bracket • M6 mounting bolt hole 	<p>--</p>	<p>GM 2006 Equinox</p>
	<ul style="list-style-type: none"> • 2.95" diameter • 4.37" length • .308 female pad mount inlet & outlet • M8 mounting bolt hole 	<p>XW4Z 19959 BA 6W4Z 19959 A</p>	<p>98-06 Lincoln LS 98-04 Jaguar</p>

Steel Automotive Dryer Features

- Designed for applications in automotive, truck cab, agriculture, construction, recreational vehicle and air conditioning unit manufacturers
- Building-block design permits customer modifications
- Available with flow-through desiccant bed or wool felt bag
- Can be engineered to manufacturer’s specifications

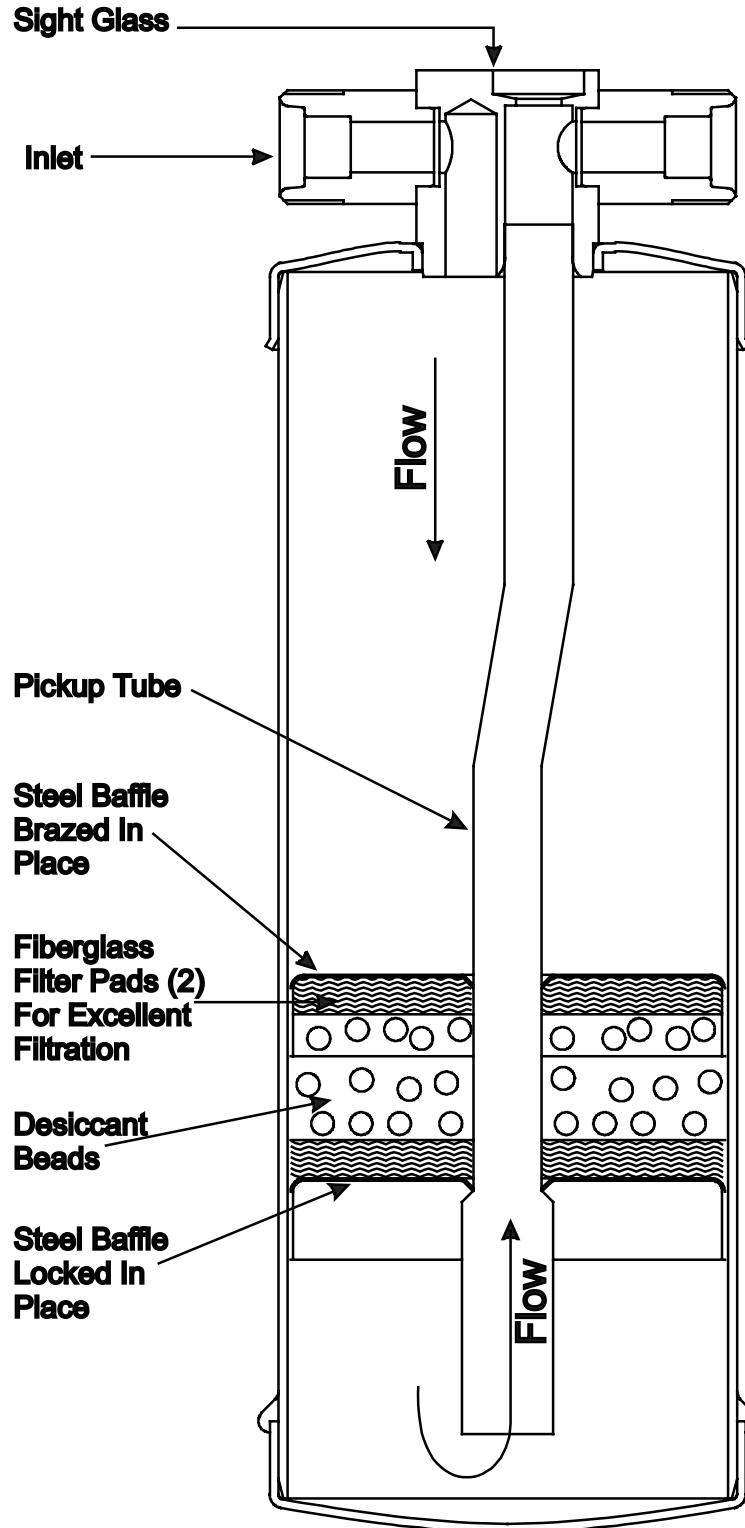

Steel Receiver Dryers

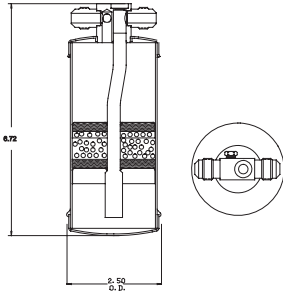
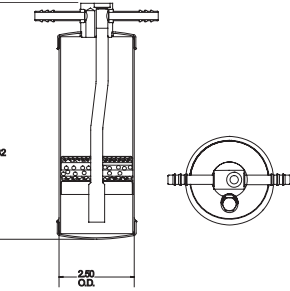
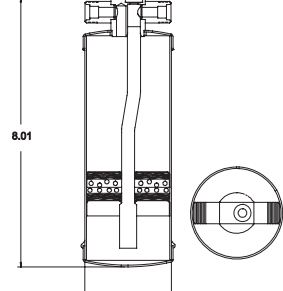
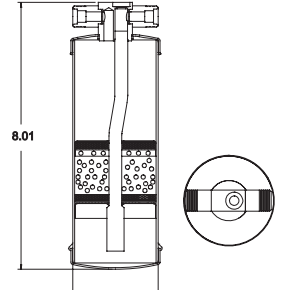
Illustration	Description	OEM No.	Application
<p>085022</p> 	<ul style="list-style-type: none"> • 2.5" diameter • 6.7" height • 3/8" male flare inlet & outlet • Fuse plug • Sight glass 	<p>23-5066</p> <p>7-158</p> <p>CF Model</p>	<p>Danhard</p> <p>Frigette</p> <p>77-82 Mack</p>
<p>085038</p> 	<ul style="list-style-type: none"> • 2.5" diameter • 7.8" height • 5/16" barb inlet • 5/16" barb outlet • 1/8" female NPT port • Sight glass 	<p>7-332</p> <p>ZvW433-433</p>	<p>Frigette</p> <p>Volkswagen</p>
<p>085041</p> 	<ul style="list-style-type: none"> • 2.5" diameter • 8.0" height • 3/8" male o-ring inlet & outlet • Sight glass 	<p>n/a</p>	<p>Generic</p>
<p>085052</p> 	<ul style="list-style-type: none"> • 2.5" diameter • 8.0" height • 3/8" male o-ring inlet & outlet • Sight glass 	<p>402492</p> <p>402537</p> <p>3039149-M91</p> <p>3105V003</p>	<p>Kysor/Westeran</p> <p>Mack</p> <p>78-81 F Series</p> <p>77-81 R Series</p> <p>Massey Ferguson</p> <p>Stople</p>

Steel Receiver Dryers

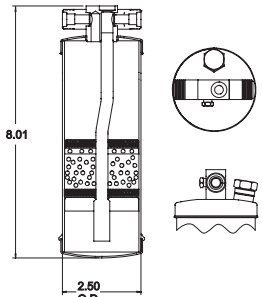
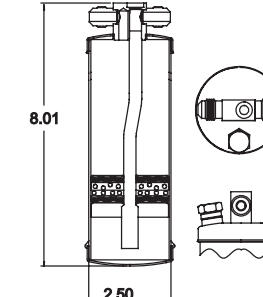
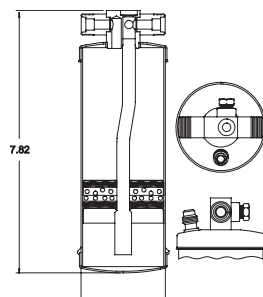
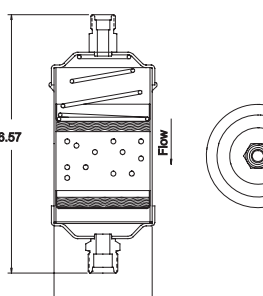
Illustration	Description	OEM No.	Application
<p>085098</p> 	<ul style="list-style-type: none"> • 2.5" diameter • 8.0" height • 3/8" male o-ring inlet & outlet • 3/8" female switch port • Fuse plug • Sight glass 	<p>A22-14425-2</p> <p>04-9054678</p>	<p>Freightliner 81-84 COE/Conv.</p> <p>Volvo/GM Truck 84-85</p>
<p>085102</p> 	<ul style="list-style-type: none"> • 2.5" diameter • 8.0" height • 3/8" male flare inlet & outlet • Sight glass • Low pressure switch port 	<p>4-4047</p>	<p>Wynn's</p>
<p>085107</p> 	<ul style="list-style-type: none"> • 2.5" diameter • 7.8" height • 3/8" male o-ring inlet & outlet • 7/16" male charge port • Fuse plug • Sight glass 	<p>BMA611-432</p>	<p>Volkswagen</p>
<p>085154</p> 	<ul style="list-style-type: none"> • 2.5" diameter • 6.57" height • 3/8" male o-ring inlet • 1/2" male o-ring outlet • Spring loaded sieve bed 	<p>15505227</p> <p>4022619</p>	<p>GMC Truck 80-91 CCOT w/in-line dryer</p> <p>Kysor/Westran</p>

Steel Receiver Dryers

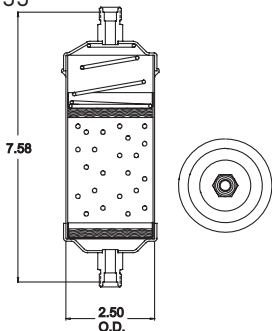
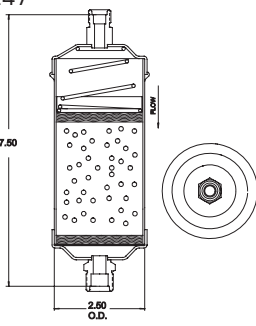
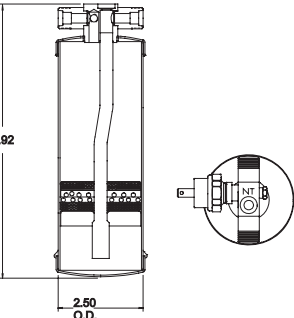
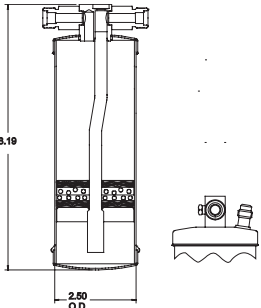
Illustration	Description	OEM No.	Application
<p>085155</p> 	<ul style="list-style-type: none"> • 2.5" diameter • 7.85" height • 3/8" male o-ring inlet & outlet • Spring-loaded sieve bed 	<p>02-1095</p>	<p>Steiger Tractor</p>
<p>085247</p> 	<ul style="list-style-type: none"> • 2.5" diameter • 7.76" height • 3/8" male o-ring inlet • 1/2" male o-ring outlet • Spring-loaded sieve bed 	<p>V70966</p>	<p>Verstaile</p>
<p>085252</p> 	<ul style="list-style-type: none"> • 2.5" diameter • 8.0" height • 3/8" male o-ring inlet & outlet • Low pressure switch • Fuse plug • Sight glass 	<p>4-4063 4-4082</p>	<p>Wynn's</p>
<p>085261</p> 	<ul style="list-style-type: none"> • 2.5" diameter • 8.2" height • 3/8" male o-ring inlet • 3/8" male o-ring outlet • 7/16" male ports (2) • Fuse plug • Sight glass 	<p>1273120</p>	<p>ARA</p>

Steel Receiver Dryers

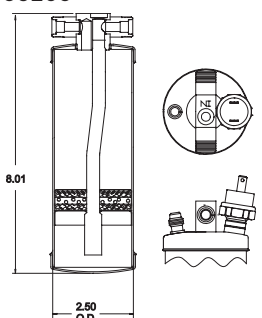
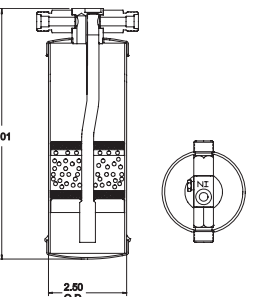
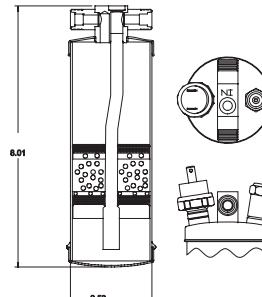
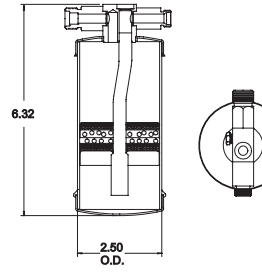
Illustration	Description	OEM No.	Application
<p>085268</p> 	<ul style="list-style-type: none"> • 2.5" diameter • 8.0" height • 3/8" male o-ring inlet & outlet • 7/16" male port • 3/8" female port, no switch • Sight glass 	<p>7-485 4-4091</p>	<p>Frigette Wynn's</p>
<p>085274</p> 	<ul style="list-style-type: none"> • 2.5" diameter • 8.0" height • 3/8" male o-ring inlet & outlet • Fuse plug • Sight glass 	<p>A22-14425-1</p>	<p>72-91 Freightliner COE</p>
<p>085293</p> 	<ul style="list-style-type: none"> • 2.5" diameter • 8.0" height • 3/8" male o-ring inlet & outlet • Switch port • High pressure relief valve • Switch installed • Sight glass 	<p>13708722</p>	<p>Volvo 81-87 240 & 260 Series</p>
<p>085324</p> 	<ul style="list-style-type: none"> • 2.5" diameter • 6.3" height • 3/8" male o-ring inlet • 1/2" male adapter • Sight glass • Fuse plug 	<p>1273235</p>	<p><u>ARA</u> RV/Motorhome Dryer</p>

Steel Receiver Dryers

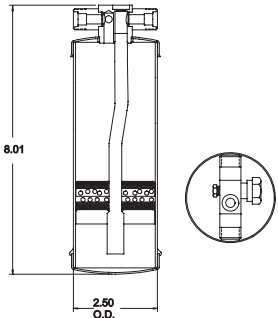
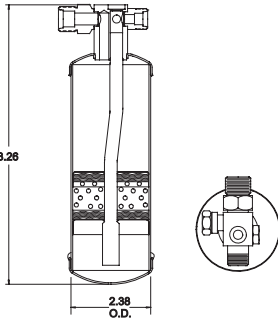
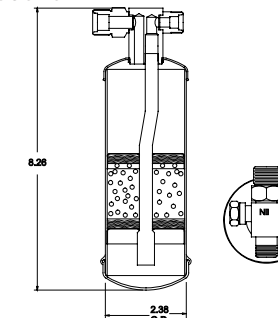
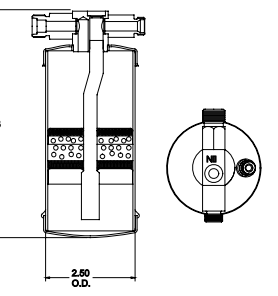
Illustration	Description	OEM No.	Application
<p>085383</p> 	<ul style="list-style-type: none"> • 2.5" diameter • 8.0" height • 5/16" male o-ring inlet & outlet • 3/8" female switch port • Sight glass • Fuse plug 	<p>0000-67-0A9A-6F</p> <p>4-4095</p>	<p><u>Mazda</u> 79-81 All</p> <p>Wynn's</p>
<p>085455</p> 	<ul style="list-style-type: none"> • 2.38" diameter • 8.25" height • M20 male o-ring inlet • M16 male o-ring outlet • 3/8" female switch port • Fuse plug • Sight glass 	<p>162460</p>	<p><u>Nissan</u> 87 Pickup</p>
<p>085616</p> 	<ul style="list-style-type: none"> • 2.38" diameter • 8.25" height • M20 male o-ring Inlet • M16 male o-ring outlet • 3/8" female switch port 	<p>192408</p>	<p><u>Nissan</u> 92 & up Pickup R-134a</p>
<p>085623</p> 	<ul style="list-style-type: none"> • 2.5" diameter • 6.23" height • 3/8" male o-ring inlet • 1/2" male adapter • M10 male switch port 	<p>33-0038A</p> <p>12546135</p>	<p>Wynn's 92 & Up GM RV Unit (R134a)</p> <p>GM Motor home</p>

Steel Receiver Dryers

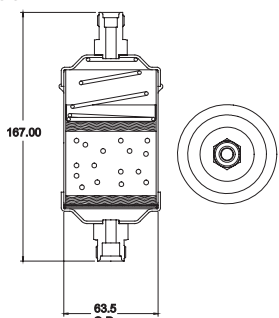
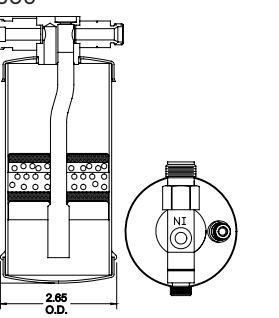
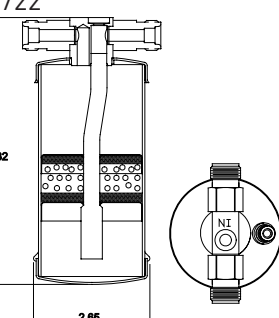
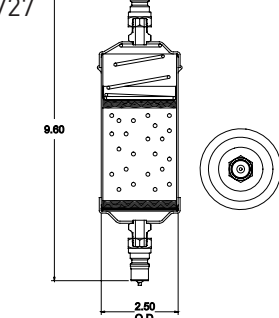
Illustration	Description	OEM No.	Application
<p>085682</p> 	<ul style="list-style-type: none"> • 2.5" diameter • 6.57" height • M18 male o-ring inlet • M20 male o-ring outlet • Spring loaded sieve bed 	<p>15982368</p>	<p>GMC 92 & Up In-line dryer</p>
<p>085686</p> 	<ul style="list-style-type: none"> • 2.5" diameter • 6.3" height • M18 male o-ring inlet • M12 male o-ring outlet • M10 male switch port • Sight glass 		<p>GM Chasis Motor Home 96 & Up</p>
<p>085722</p> 	<ul style="list-style-type: none"> • 2.5" diameter • 6.3" height • M18 male inlet fitting • M18 male outlet fitting • M10 male switch port • Sight glass 		<p>GM Chasis Motor Home 96 & Up</p>
<p>085727</p> 	<ul style="list-style-type: none"> • 2.5" diameter • 9.6" height • Male quick disconnect inlet & outlet • Spring loaded sieve bed 	<p>18-03841</p>	<p>Peterbilt 94 & Up Optional</p>

Steel Receiver Dryers

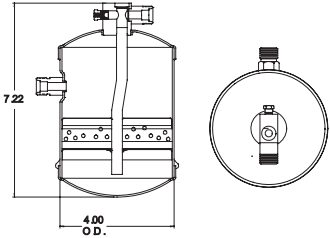
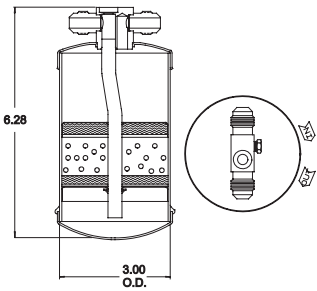
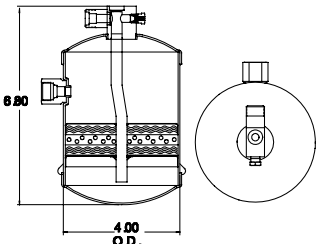
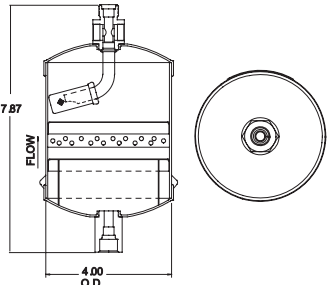
Illustration	Description	OEM No.	Application
<p>088001</p> 	<ul style="list-style-type: none"> • 4.0" diameter • 8.8" height • 3/8" male o-ring side inlet • 3/8" male o-ring outlet • Fuse plug • Sight glass 	<p>402527 402708</p> <p>1283028C2</p>	<p>Kysor/Westran</p> <p>CNH</p>
<p>088011</p> 	<ul style="list-style-type: none"> • 3" diameter • 6.3" height • 3/8" flare inlet • 3/8" flare outlet • Fuse plug 	<p>D6NN-19959-A C6TZ-19959-A</p> <p>300181 62418-G1 926384-C1 AR45867 250929-M91</p> <p>301319-C91 300181-0 130217 3105V002 30-3127680/ 30-3224724</p> <p>41-007374</p>	<p>Ford Tractor Ford Truck 69-72 L Series 73-79 L Series W/Rooftop Cond. 66-73 W-WT 900-1000</p> <p>Hiniker Hupp International Harvester John Deere Massey Ferguson Navistar 74-77 Fleetstar 2010 & 2050 Royal Industries Ford New Holland Stopler White Farm</p> <p>Year-Around Cab</p>
<p>088022</p> 	<ul style="list-style-type: none"> • 3.0" diameter • 6.3 height • 3/8" female o-ring inlet • 3/8" male o-ring outlet • Sight glass • Fuse plug 	<p>118304-C2</p>	<p>International Harvester</p>
<p>088033</p> 	<ul style="list-style-type: none"> • 4.0" diameter • 8.0" height • 3/8" female o-ring inlet • 3/8" male o-ring outlet • Double sight glass 	<p>70268464</p>	<p>Deutz/Allis</p>

Steel Receiver Dryers

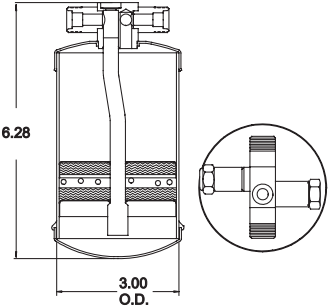
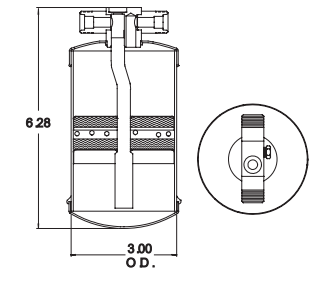
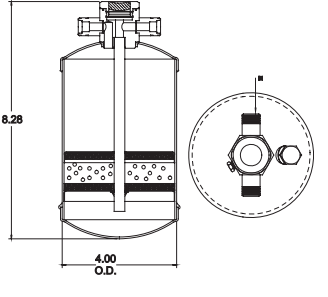
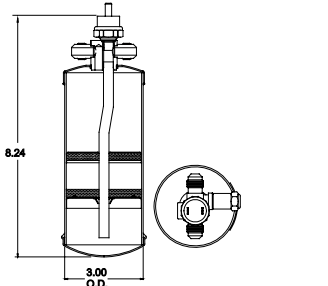
Illustration	Description	OEM No.	Application
<p>088037</p> 	<ul style="list-style-type: none"> • 3.0" diameter • 6.3" height • 3/8" male o-ring inlet & outlet • 3/8" female switch port • High pressure relief valve 	<p>56980 HV32890 402752 221RD32</p>	<p>Berstrom Evans/Temp Con Kysor/Westran <u>Mack</u> 77-84 R, V, DM Series</p>
<p>088038</p> 	<ul style="list-style-type: none"> • 3.0" diameter • 6.3" height • 3/8" male o-ring inlet & outlet • Sight glass • Fuse plug 	<p>HV31147 D3HZ-19959-A D3HZ-19958-A 399425-C91 RD-5-3843-0</p>	<p>Evans/Temp Con <u>Ford Truck</u> 73-79 L Series 73-79 W Series <u>Navistar</u> 74-77 Fleetstar 2010 & 2050 Red Dot</p>
<p>088040</p> 	<ul style="list-style-type: none"> • 4.0" diameter • 8.3" height • 3/8" male o-ring inlet & outlet • Low pressure switch port • Combination sight glass & moisture indicator • Fuse plug 	<p>696524</p>	<p>Ford New Holland</p>
<p>088041</p> 	<ul style="list-style-type: none"> • 3.0" diameter • 8.2" height • 3/8" male flare inlet & outlet • High pressure relief valve • Low pressure switch • Side sight glass 	<p>30-3347710 72161835</p>	<p>White Farm Agco</p>

Steel Receiver Dryers

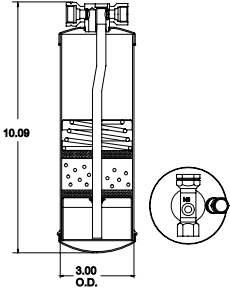
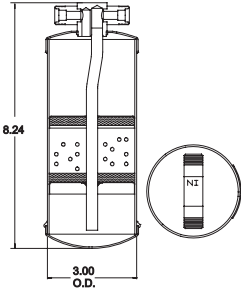
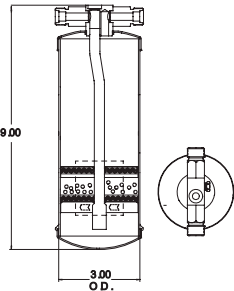
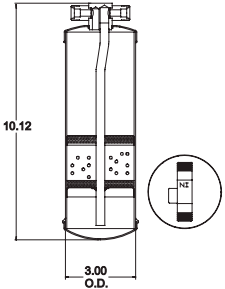
Illustration	Description	OEM No.	Application
<p>088048</p> 	<ul style="list-style-type: none"> • 3.0" diameter • 10.1" height • 11/16" female o-ring inlet • 3/8" female o-ring outlet • High pressure relief valve • Sight glass 	<p>402505 454613-C1</p>	<p>Kysor/Westran</p> <p><u>Navistar</u> 81-87 All Models 77-91 S Series 74-91 Transtar 4200 & 4300 73-81 Transtar 4070 A & B</p>
<p>088056</p> 	<ul style="list-style-type: none"> • 3.0" diameter • 8.2" height • 3/8" male o-ring inlet & outlet 	<p>W900B 18-02346</p>	<p>Kenworth 82-91 Peterbilt 81-91 362</p>
<p>088069</p> 	<ul style="list-style-type: none"> • 3.0" diameter • 9.0" height • 3/8" male o-ring inlet & outlet • Fuse plug • Sight glass 	<p>1634695M1 71193543</p>	<p>Massey Ferguson Agco</p>
<p>088079</p> 	<ul style="list-style-type: none"> • 3.0" diameter • 10.1" height • 3/8" male o-ring inlet & outlet • Side sight glass 	<p>K251-459 JA1305</p>	<p><u>Kenworth</u> 70-74</p> <p>Paccar</p>

Steel Receiver Dryers

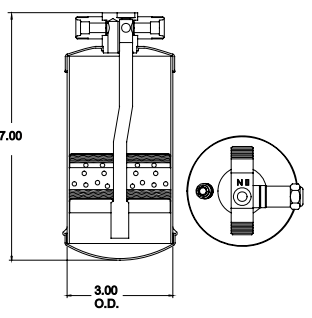
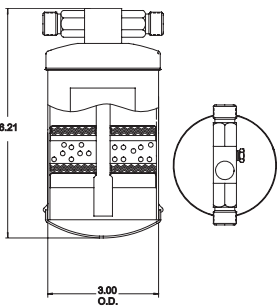
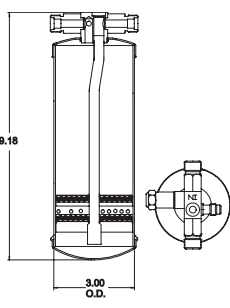
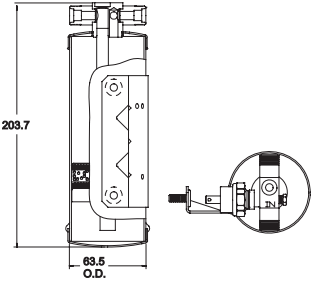
Illustration	Description	OEM No.	Application
<p>088104</p> 	<ul style="list-style-type: none"> • 3.0" diameter • 7.0" height • 3/8" male o-ring inlet & outlet • Sight glass • High pressure relief valve • 7/16" male port 	<p>HV33614</p>	<p>Evans/Temp Con</p>
<p>088115</p> 	<ul style="list-style-type: none"> • 3.0" diameter • 6.2" height • 3/8" male o-ring inlet & outlet • Fuse plug • Sight glass 	<p>402496</p>	<p>Kysor/Westran</p>
<p>088116</p> 	<ul style="list-style-type: none"> • 3.0" diameter • 9.2" height • 3/8" male o-ring inlet & outlet • Gage port • High pressure relief valve 	<p>61510-0006</p>	<p>Volvo/GM Truck</p>
<p>088118</p> 	<ul style="list-style-type: none"> • 2.5" diameter • 8.0" height • 3/8" male o-ring inlet & outlet • Fuse plug • Bracket • Low pressure switch • Sight glass 	<p>000-67-A91A-6P 4-4100</p>	<p>Mazda 79-81 Wynn's</p>

Steel Receiver Dryers

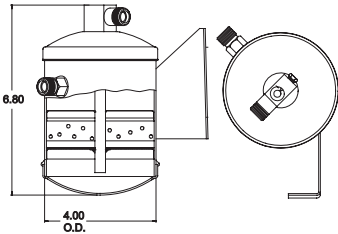
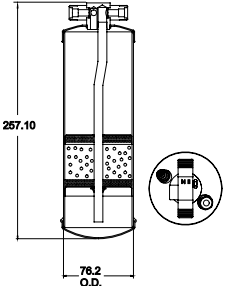
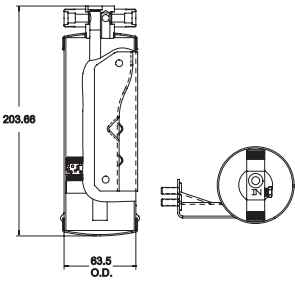
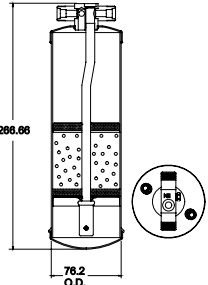
Illustration	Description	OEM No.	Application
<p>088126</p> 	<ul style="list-style-type: none"> • 4.0" diameter • 6.8" height • 3/8" male o-ring inlet & outlet • Fuse plug • Bracket • Sight glass 	E4NN-19825AA	(CNH) Ford Tractor
<p>088133</p> 	<ul style="list-style-type: none"> • 3.0" diameter • 10.1" height • 3/8" male o-ring inlet & outlet • Fuse plug • Gage port • Side sight glass 	K251-521	Kenworth 70-74
<p>088151</p> 	<ul style="list-style-type: none"> • 2.5" diameter • 8.0" height • 3/8" male o-ring inlet & outlet • Fuse plug • Bracket • Sight glass 	UC8661500A	Mazda Truck
<p>088161</p> 	<ul style="list-style-type: none"> • 3.0" diameter • 10.5" height • 3/8" male o-ring inlet & outlet • Fuse plug • 2 charge ports (7/16" male) 	71355100	Deutz/Allis

Steel Receiver Dryers

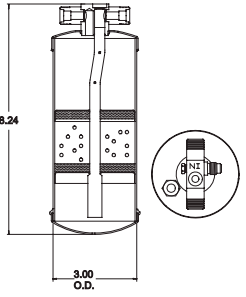
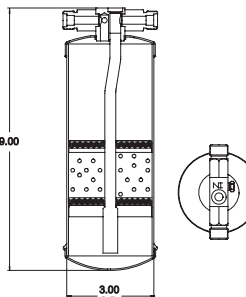
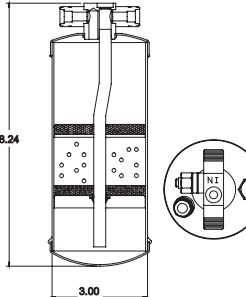
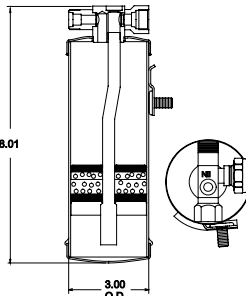
Illustration	Description	OEM No.	Application
<p>088175</p> 	<ul style="list-style-type: none"> • 3.0" diameter • 10.5" height • 3/8" male o-ring inlet & outlet • Fuse plug • 7/16" male charge port • Sight glass 	<p>61506-3402-000</p>	<p>Western Star 88-91 All</p>
<p>088176</p> 	<ul style="list-style-type: none"> • 3.0" diameter • 9.0" height • 3/8" male o-ring inlet & outlet • Fuse plug • Sight glass 	<p>9672494</p>	<p>CNH</p>
<p>088193</p> 	<ul style="list-style-type: none"> • 3.0" diameter • 8.2" height • 3/8" male o-ring inlet & outlet • High pressure relief valve • 3/8" female switch port 	<p>PH 088193 00</p>	<p>89 Freightliner (A22-28796-000)</p>
<p>088204</p> 	<ul style="list-style-type: none"> • 2.5" diameter • 8.0" height • 3/8" male o-ring inlet • 3/8" female o-ring outlet • Low pressure switch • Bracket • Sight glass 	<p>4070934</p>	<p>Saab 89-91 900 Series</p>

Steel Receiver Dryers

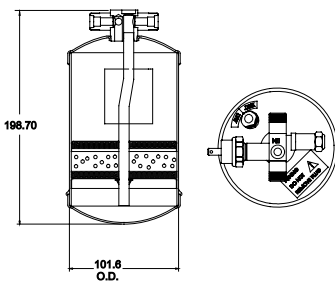
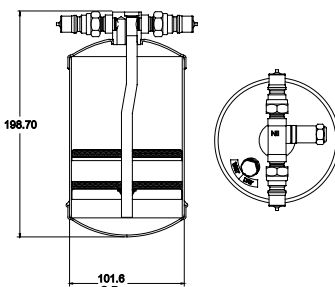
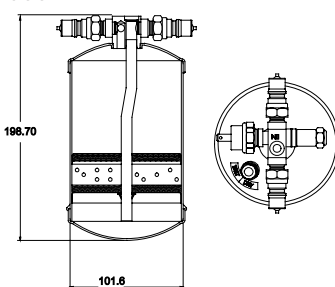
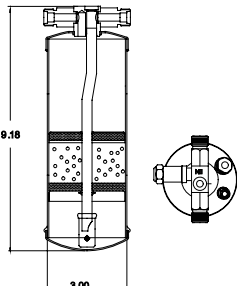
Illustration	Description	OEM No.	Application
<p>088209</p> 	<ul style="list-style-type: none"> • 4.0" diameter • 7.8" height • 3/8" male o-ring inlet & outlet • 3/8" female switch port • Low pressure switch • High pressure relief valve • Moisture indicator • Sight glass 	<p>106-5534</p>	<p>Caterpillar</p>
<p>088210</p> 	<ul style="list-style-type: none"> • 4.0" diameter • 7.8" height • Male quick disconnect inlet & outlet • High pressure relief valve • Moisture indicator • Sight glass 	<p>106-5532</p>	<p>Caterpillar</p>
<p>088211</p> 	<ul style="list-style-type: none"> • 4.0" diameter • 7.8" height • Male quick disconnect inlet & outlet • 3/8" female switch port • High pressure relief valve • Moisture indicator • Low pressure switch • Sight glass 	<p>106-5533</p>	<p>Caterpillar</p>
<p>088214</p> 	<ul style="list-style-type: none"> • 3.0" diameter • 9.2" height • 3/8" male o-ring inlet & outlet • 7/16" male port • High pressure relief valve • Moisture indicator • Sight glass 	<p>61510-0008</p>	<p>Volvo/GM Truck 90-91</p>

Steel Receiver Dryers

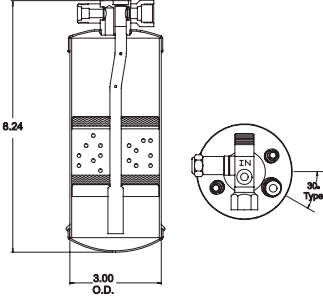
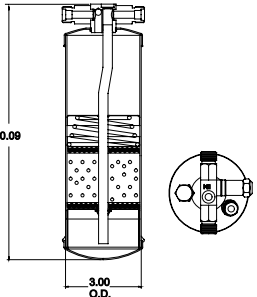
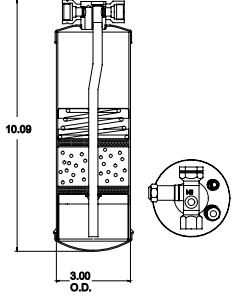
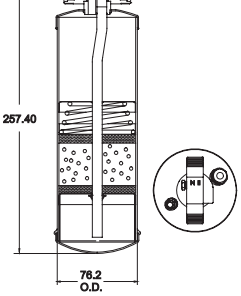
Illustration	Description	OEM No.	Application
<p>088215</p> 	<ul style="list-style-type: none"> • 3.0" diameter • 8.2" height • 3/8" male o-ring inlet • 3/8" female o-ring outlet • High pressure relief valve • Sight glass • 2 gage ports (7/16" male) 	<p>PH 088215 02</p>	<p>90-91 Freightliner (A22-317199-000)</p>
<p>088228</p> 	<ul style="list-style-type: none"> • 3.0" diameter • 10.1" height • 3/8" male o-ring inlet & outlet • 3/8" female switch port • High pressure relief valve • Moisture indicator • Sight glass 	<p>K256-566</p>	<p>Kenworth</p>
<p>088229</p> 	<ul style="list-style-type: none"> • 3.0" diameter • 10.1" height • 1 1/16" female o-ring inlet • 3/8" female o-ring outlet • High pressure relief valve • Moisture indicator • 3/8" male quick charge port • Sight glass 	<p>--</p>	<p>Heavy Truck A/C Kits</p>
<p>088238</p> 	<ul style="list-style-type: none"> • 3.0" diameter • 10.1" height • 3/8" male o-ring inlet & outlet • 7/16" male port • Fuse plug • Moisture indicator • Side sight glass 	<p>221RD331</p>	<p>Mack 93 & Up</p>

Steel Receiver Dryers

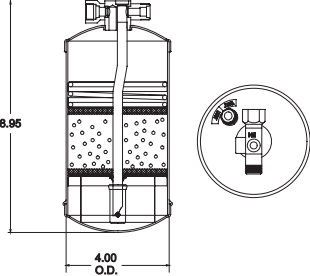
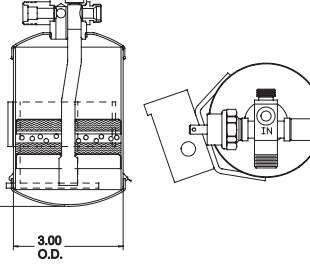
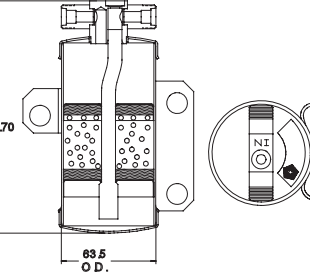
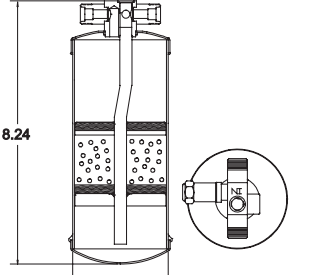
Illustration	Description	OEM No.	Application
<p>088239</p> 	<ul style="list-style-type: none"> • 4.0" diameter • 8.9" height • 3/8" female o-ring inlet • 3/8" male o-ring outlet • Moisture indicator • Side sight glass • Top sight glass 	<p>AT162848</p>	<p>John Deere 91 +</p>
<p>088240</p> 	<ul style="list-style-type: none"> • 3.0" diameter • 5.7" height • 3/8" male o-ring inlet • 1/2" male adapter • 3/8" female switch port • High pressure relief valve • Low pressure switch • Bracket • Sight glass 	<p>04773767</p>	<p>Jeep 90-91</p>
<p>088245</p> 	<ul style="list-style-type: none"> • 2.5" diameter • 6.1" height • 3/8" male o-ring inlet & outlet • Bracket • Sight glass 	<p>04773656</p>	<p>Chrysler 91 Dynasty, New Yorker</p>
<p>088248</p> 	<ul style="list-style-type: none"> • 3.0" diameter • 8.2" height • 3/8" male o-ring inlet & outlet • High pressure relief valve • 3/8" female switch port • Side sight glass 	<p>18-01800 RD-5-3593-0</p>	<p><u>Peterbilt</u> 77-80 283,352 77-91 289,353,348 Red Dot</p>

Steel Receiver Dryers

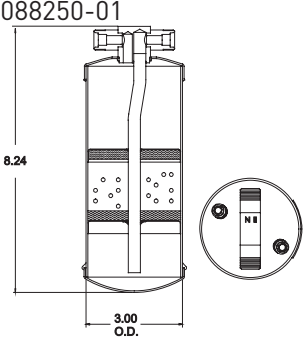
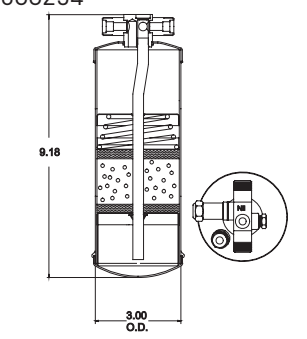
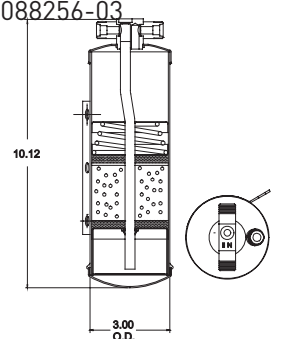
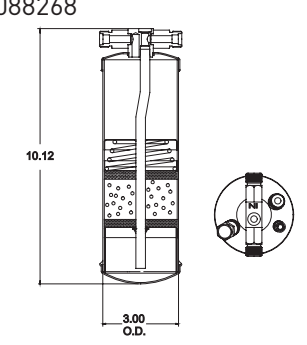
Illustration	Description	OEM No.	Application
<p>088250-01</p> 	<ul style="list-style-type: none"> • 3.0" diameter • 8.2" height • 3/8" male o-ring inlet & outlet • High pressure relief valve • Two 7/16" male ports 	<p>18-03619</p>	<p>Peterbilt Class 8</p>
<p>088254</p> 	<ul style="list-style-type: none"> • 3.0" diameter • 9.2" height • 3/8" male o-ring inlet & outlet • High pressure relief valve • Moisture indicator • 1/8" Female NPT 	<p>221 RD 333</p>	<p>Mack</p>
<p>088256-03</p> 	<ul style="list-style-type: none"> • 3.0" diameter • 10.1" height • 3/8" male o-ring inlet & outlet • Bracket • Moisture indicator • Sight glass 	<p>F2HZ-19959-A</p>	<p>Ford Truck 93 & Up</p>
<p>088268</p> 	<ul style="list-style-type: none"> • 3.0" diameter • 10.1" height • 3/8" male o-ring inlet & outlet • 7/16" male port • High pressure relief valve • Moisture indicator • Sight glass 	<p>221 RD 334</p>	<p>Mack</p>

Steel Receiver Dryers

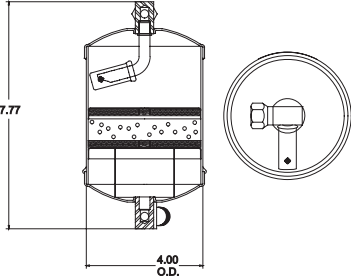
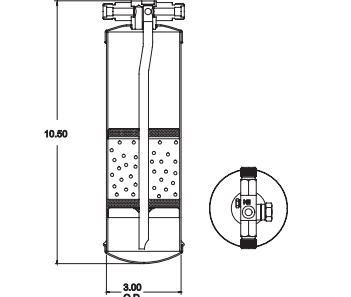
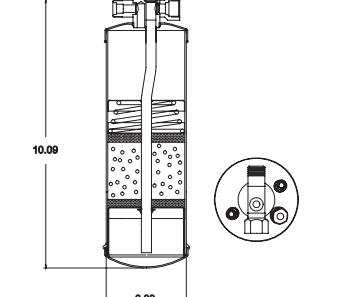
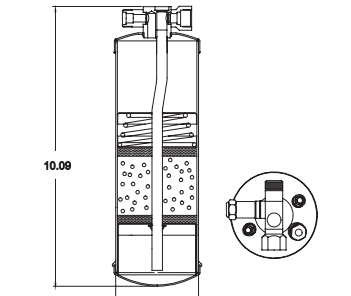
Illustration	Description	OEM No.	Application
<p>088271</p> 	<ul style="list-style-type: none"> • 4.0" diameter • 7.77" height • 3/8" male o-ring inlet • 3/8" female o-ring outlet • Horizontal type 	1990758C2	CNH
<p>088276</p> 	<ul style="list-style-type: none"> • 3.0" diameter • 10.5" height • 3/8" male o-ring inlet & outlet • 3/8" female switch port • Fuse plug • Sight glass 	9827053	CNH
<p>088281</p> 	<ul style="list-style-type: none"> • 3.0" diameter • 10.1" height • 3/8" male o-ring inlet • 3/8" female o-ring outlet • two 7/16 male ports • Sight glass • 2 Gage Ports 	PH 088281 00	Freightliner 93-94 Class 8
<p>088282</p> 	<ul style="list-style-type: none"> • 3.0" diameter • 10.1" height • 3/8" male o-ring inlet • 3/8" female o-ring outlet • Sight glass • Two 7/16" ports • High pressure relief valve 	PH08828200	Freightliner 93-94 Class 8

Steel Receiver Dryers

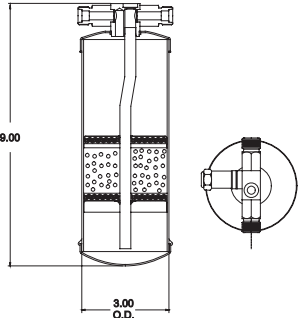
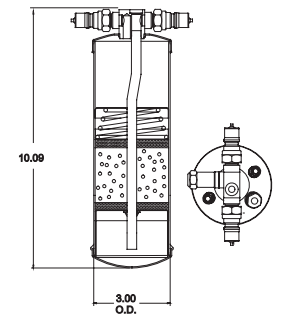
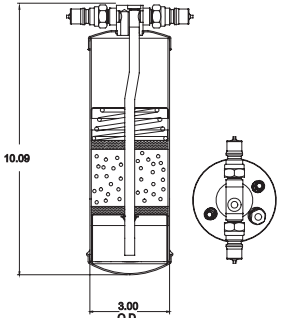
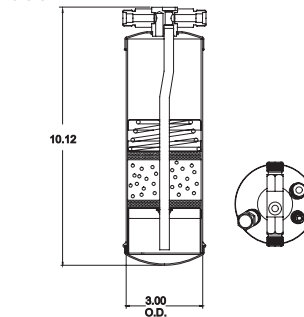
Illustration	Description	OEM No.	Application
<p>088290</p> 	<ul style="list-style-type: none"> • 3.0" diameter • 9.0" height • 3/8" male o-ring inlet & outlet • High pressure relief valve • Sight glass • 60 cc Pag oil 	<p>9705765</p>	<p>CNH/Versatile 93 & Up Tractor</p>
<p>088292</p> 	<ul style="list-style-type: none"> • 3.0" diameter • 10.1" height • Male quick disconnect inlet & outlet • Two 7/16" ports • High pressure relief valve • Sight glass 	<p>PH 088292 00</p>	<p>Freightliner Class 8</p>
<p>088293</p> 	<ul style="list-style-type: none"> • 3.0" diameter • 10.1" height • Male quick disconnect inlet & outlet • Two 7/16" ports • Sight glass 	<p>PH08829300</p>	<p>Freightliner 93-94 Class 8</p>
<p>088294</p> 	<ul style="list-style-type: none"> • 3.0" diameter • 10.1" height • 3/8" male o-ring inlet & outlet • M10 switch port • High pressure relief valve • Sight glass • Moisture indicator 	<p>221 RD 335</p>	<p>Mack 93 & Up R134a Only</p>

Steel Receiver Dryers

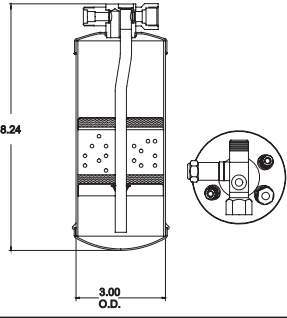
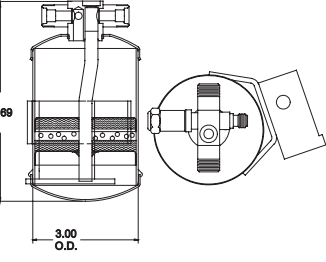
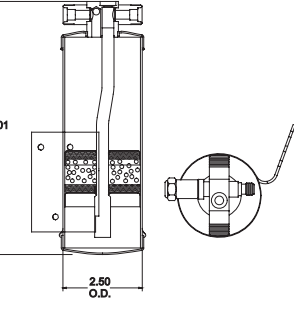
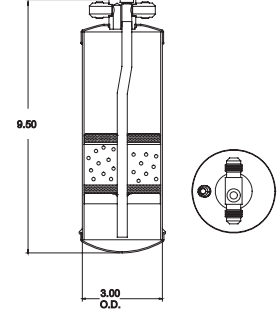
Illustration	Description	OEM No.	Application
<p>088301</p> 	<ul style="list-style-type: none"> • 3.0" diameter • 8.2" height • 3/8" male o-ring inlet • 3/8" female o-ring outlet • Two M10 switch ports • High pressure relief valve • Moisture indicator 	18-03783	93 Peterbilt
<p>088310</p> 	<ul style="list-style-type: none"> • 3.0" diameter • 5.7" height • 3/8" male o-ring inlet & outlet • M10 switch port • Bracket • High pressure relief valve • Sight glass 	55036112 04797002	Jeep 94 & Up XJ Series
<p>088311</p> 	<ul style="list-style-type: none"> • 2.5" diameter • 7.8" height • 3/8" male o-ring inlet & outlet • M10 switch port • High pressure relief valve • Sight glass • Bracket 	55036268 04797003	Jeep 94 & Up Wrangler Series
<p>088320</p> 	<ul style="list-style-type: none"> • 3.0" diameter • 9.5" height • 3/8" male flare inlet & outlet • 7/16" male port • Sight glass 	60-5818T4	CNH

Steel Receiver Dryers

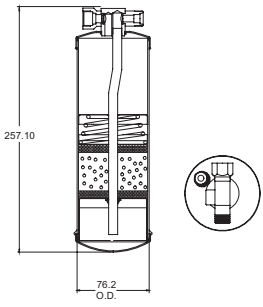
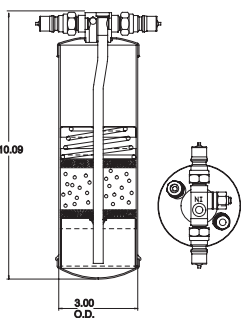
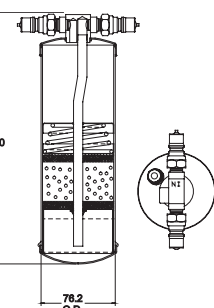
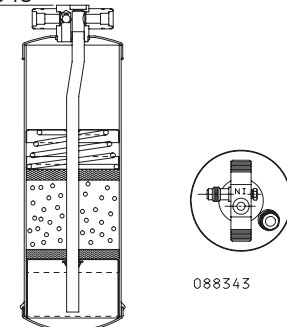
Illustration	Description	OEM No.	Application
<p>088324</p> 	<ul style="list-style-type: none"> • 3.0" diameter • 10.1" height • 3/8" female o-ring inlet • 3/8" male o-ring outlet • Moisture indicator • Side sight glass 	<p>K251-571</p>	<p>Kenworth 94 & Up Class 8</p>
<p>088334</p> 	<ul style="list-style-type: none"> • 3.0" diameter • 10.1" height • Male quick disconnect inlet & outlet • 134A charge port • Sight glass • High pressure relief valve • Moisture indicator 	<p>--</p>	<p>Heavy Truck A/C Kit</p>
<p>088341</p> 	<ul style="list-style-type: none"> • 3.0" diameter • 10.1" height • Male quick disconnect inlet & outlet • Moisture indicator • Side sight glass 	<p>--</p>	<p>Kenworth 95-97 Class 8</p>
<p>088343</p> 	<ul style="list-style-type: none"> • 3.0" diameter • 10.1" height • 3/8" male o-ring inlet & outlet • 7/16" male port • Sight glass • Fuse plug • Moisture indicator 	<p>RD-5-7517-1</p>	<p>Red Dot heavy truck</p>

Steel Receiver Dryers

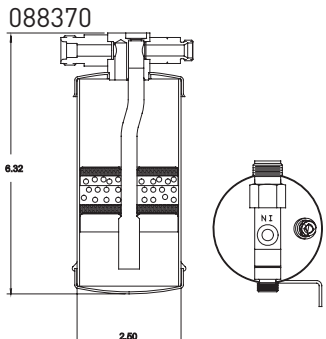
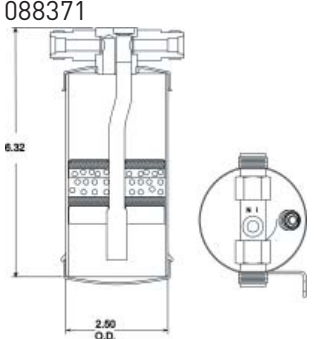
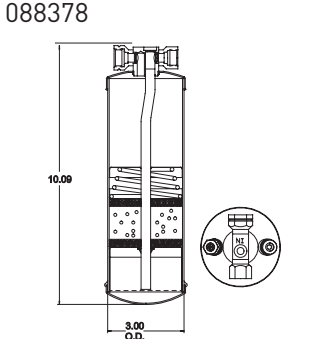
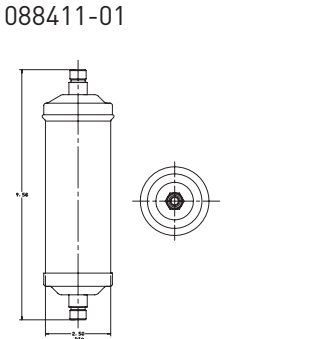
Illustration	Description	OEM No.	Application
<p>088370</p> 	<ul style="list-style-type: none"> • 2.5" diameter • 6.3" height • M18 male o-ring inlet • M12 male adapter outlet • M10 male switch port • Bracket • Sight glass 	<p>33-0382A 12375379</p>	<p>Wynn's 96 GM RV Chasis GM RV</p>
<p>088371</p> 	<ul style="list-style-type: none"> • 2.5" diameter • 6.3" height • M18 male o-ring inlet & outlet • M10 male switch port • Sight glass • Bracket 	<p>33-0383A</p>	<p>Wynn's 96 GM RV Chasis</p>
<p>088378</p> 	<ul style="list-style-type: none"> • 3.0" diameter • 10.1" height • 11/16" female o-ring inlet • 3/8" female o-ring outlet • High pressure relief valve • R134a charge port • Sight glass 	<p>1693117-C1</p>	<p>Navistar 89-96 Class 8</p>
<p>088411-01</p> 	<ul style="list-style-type: none"> • 3.0" diameter • 9.56" height • 3/8" male o-ring inlet & outlet • horizontal dryer 		

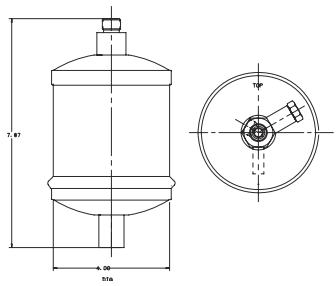
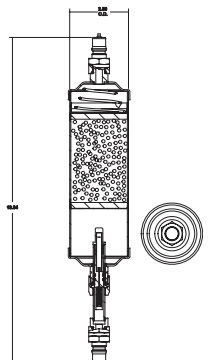
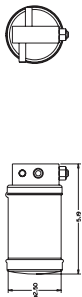
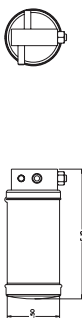

Steel Receiver Dryers

Illustration	Description	OEM No.	Application
<p>088417</p> 	<ul style="list-style-type: none"> • 4.0" diameter • 7.87" height • 3/8" female o-ring inlet • 3/8" male o-ring outlet • 3/8" female switch port 	<p>70264644</p>	<p>Agco</p>
<p>088434</p> 	<ul style="list-style-type: none"> • 2.5" diameter • 13.8" height • Male quick disconnect inlet & outlet • Orifice tube assembly 	<p>175-7162</p>	<p>Caterpillar 92 & Up</p>
<p>088448</p> 	<ul style="list-style-type: none"> • 2.5" diameter • 5.2" height • Pad mount with bolt inlet & outlet • High pressure relief valve 	<p>04798591AC</p>	<p>83 Dodge Sportsman / Plymouth Voyager</p> <p>82-80 Newport, New Yorker, Grand Fury</p> <p>79 Newport, New Yorker Cordoba, Charger</p> <p>89-72 Turismo, Omni, Horizon;</p> <p>81-88 Full Size Vans</p>
<p>088449</p> 	<ul style="list-style-type: none"> • 2.5" diameter • 5.2" height • Pad mount with bolt inlet & outlet • High pressure relieve valve 	<p>04773664</p>	<p>80-88 Omni , Horizon</p>

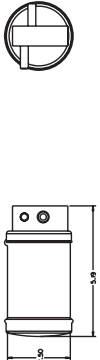
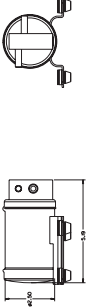
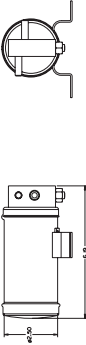
Steel Receiver Dryers

Illustration	Description	OEM No.	Application
088450 	<ul style="list-style-type: none"> • 2.5" diameter • 6.2" height • Pad mount with bolt inlet & outlet 	55036003AC	89-90 Omni, Horizon
088451 	<ul style="list-style-type: none"> • 2.5" diameter • 5.2" height • Pad mount with bolt inlet & outlet 	04361336	91-93 Mini Ram Van 89-92 Ram Charger Van
088452 	<ul style="list-style-type: none"> • 2.5" diameter • 5.2" height • Pad mount with bolt inlet & outlet • Bracket 	04773669AC	91-93 Fifth Ave, Imperial, New Yorker, Dynasty 91-93 Lebaron, Daytona, Shadow, Spirit, Acclaim 91-92 Caravan, Sundance
088455 	<ul style="list-style-type: none"> • 2.5" diameter • 6.2" height • Pad mount with bolt inlet & outlet • High pressure relief valve • Bracket 	04798590AC	84-88 Dakota, Caravan, Voyager 86-88 Shadow, Sundance; 85-88 Lancer 83-88 Aires, 600 Lebaron, New Yorker, Reliant 88 Dynasty

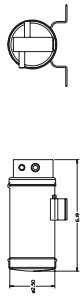
Steel Receiver Dryers

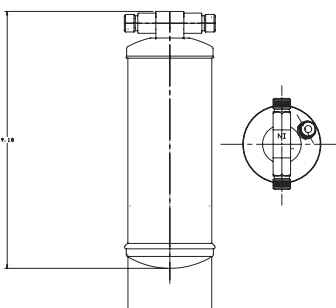
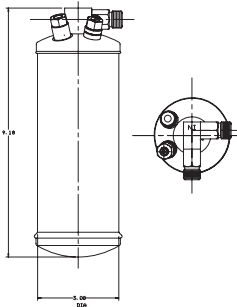
Illustration	Description	OEM No.	Application
<p>088456</p> 	<ul style="list-style-type: none"> • 2.5" diameter • 6.2" height • Pad mount with bolt inlet & outlet • Bracket 		<p>89-90 Mini Ram Van</p> <p>89-93 Dakota</p> <p>89-90 New Yorker</p> <p>90 Fifth Ave, Dynasty, Imperial</p>
<p>088476</p> 	<ul style="list-style-type: none"> • 2.5" diameter • 6.2" height • Pad mount with bolt inlet & outlet • Bracket 	<p>04677138AB</p>	<p>93-94 Spirit, Shadow, Labaron</p> <p>93-95 Voyager, Caravan</p> <p>94-95 Acclaim</p>
<p>088485</p> 	<ul style="list-style-type: none"> • 3.0" diameter • 9.2" height • 3/8" male o-ring inlet & outlet • Moisture indicator 	<p>20447319</p>	<p>Volvo Truck Class 8</p>
<p>088491</p> 	<ul style="list-style-type: none"> • 3.0" diameter • 9.2" height • 3/8" male o-ring inlet & outlet • High pressure relief valve • Moisture indicator 	<p>20407205</p>	<p>Volvo Truck Class 8</p>

Steel Receiver Dryers

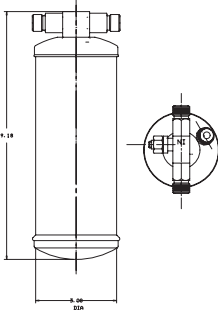
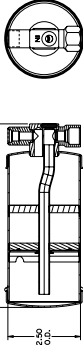
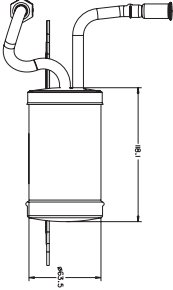
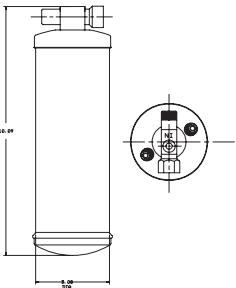
Illustration	Description	OEM No.	Application
<p>088492</p> 	<ul style="list-style-type: none"> • 3.0" diameter • 9.2" height • 3/8" male o-ring inlet & outlet • High pressure relief valve • Moisture indicator 	<p>20407203</p>	<p>Autocar Truck Class 8</p>
<p>088501</p> 	<ul style="list-style-type: none"> • 2.5" diameter • 6.3" height • 3/8" male o-ring inlet • 3/8" female o-ring outlet • Sight glass • Leak detect dye 	<p>82023593</p>	<p>CNH Tractor</p>
<p>088528</p> 	<ul style="list-style-type: none"> • 2.5" diameter • 4.6" height • 3/8" female spring lock inlet • 3/8" female swivel nut • Bracket 	<p>04797148AB</p>	<p>Chrysler</p>
<p>088535</p> 	<ul style="list-style-type: none"> • 3.0" diameter • 10.1" height • 3/8" male o-ring • 3/8" female o-ring • Two M10 male ports • Sight glass 	<p>PH 088535 00</p>	<p>Freightliner Class 8</p>

Steel Receiver Dryers

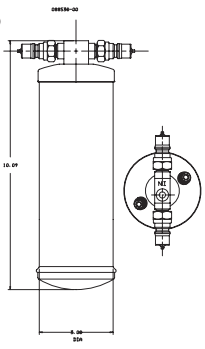
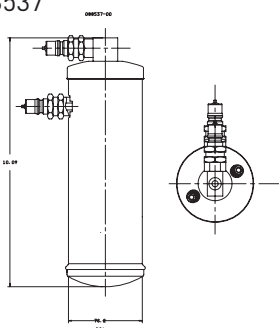
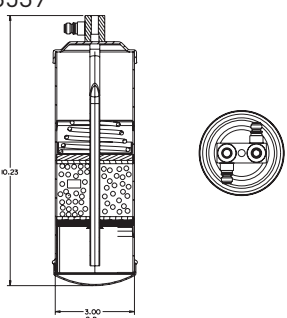
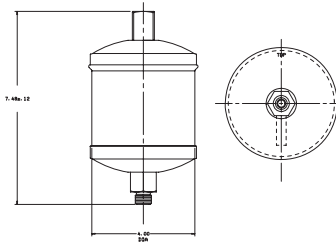
Illustration	Description	OEM No.	Application
<p>088536</p> 	<ul style="list-style-type: none"> • 3.0" diameter • 10.1" height • Male quick disconnect inlet & outlet • Two M10 male ports • Sight glass 	<p>PH 088536 00</p>	<p>Freightliner Class 8</p>
<p>088537</p> 	<ul style="list-style-type: none"> • 3.0" diameter • 10.1" height • Male quick disconnect inlet & outlet • Two M10 male ports • Sight glass 	<p>PH 088537 00</p>	<p>Freightliner Class 8</p>
<p>088539</p> 	<ul style="list-style-type: none"> • 3.0" diameter • 10.2" height • 3/8" slimline inlet & outlet ports • Two M10 switch ports • Leak detection dye 	<p>PH 088539 00</p>	<p>2003-Current Freightliner Class 8</p>
<p>088544</p> 	<ul style="list-style-type: none"> • 4.0" diameter • 7.48" height • 3/8" female o-ring inlet • 3/8" male o-ring outlet • Leak detection dye 	<p>RE214439</p>	<p>John Deere</p>

Steel Receiver Dryers

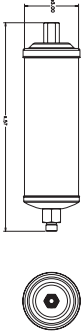
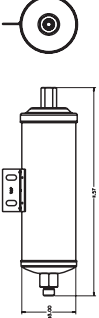
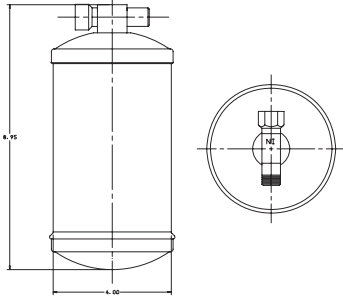
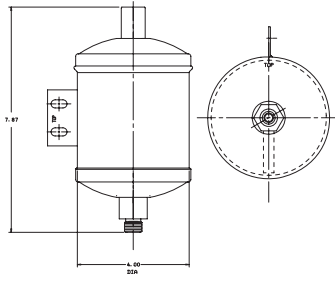
Illustration	Description	OEM No.	Application
<p>088545</p> 	<ul style="list-style-type: none"> • 3.0" diameter • 11.57" height • 3/8" female o-ring inlet • 3/8" male o-ring outlet • Leak detection dye • Horizontal dryer 	<p>RE214440</p>	<p>John Deere</p>
<p>088549</p> 	<ul style="list-style-type: none"> • 3.0" diameter • 11.57" height • 3/8" female o-ring inlet • 3/8" male o-ring outlet • Bracket • Leak detection dye • Horizontal dryer 	<p>AL163559</p>	<p>John Deere</p>
<p>088550</p> 	<ul style="list-style-type: none"> • 4.0" diameter • 8.9" height • 3/8" female o-ring inlet • 3/8" male o-ring outlet 	<p>AH211387</p>	<p>John Deere</p>
<p>088552</p> 	<ul style="list-style-type: none"> • 4.0" diameter • 7.87" height • 3/8" female o-ring inlet • 3/8" male o-ring outlet • Bracket 	<p>AL162467</p>	<p>John Deere</p>

Steel Receiver Dryers

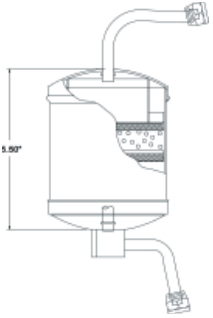
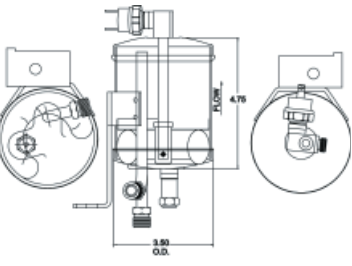
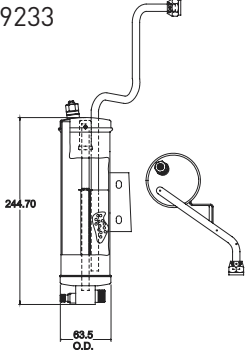
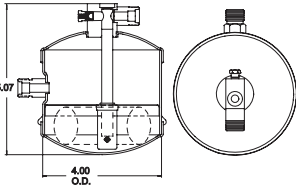
Illustration	Description	OEM No.	Application
<p>089033</p> 	<ul style="list-style-type: none"> • 4.0" diameter • 9.7" height • 3/8" female swivel nut inlet & outlet • Horizontal type 	<p>E2NN-19825-AA</p>	<p>Ford Tractor</p>
<p>089086</p> 	<ul style="list-style-type: none"> • 3.0" diameter • 6.3" height • 3/8" male o-ring Inlet • 1/2" male adapter outlet • 3/8" female switch port • LP switch • Sight glass • High pressure relief valve • Bracket 	<p>04773765</p>	<p>Jeep 87-88 XJ Series I-6</p>
<p>089233</p> 	<ul style="list-style-type: none"> • 2.5" diameter • 14.7" height • 3/8" female swivel nut inlet • 3/8" male o-ring outlet • 7/16" male port • High pressure relief valve • Sight glass • Bracket 	<p>04797001</p>	<p>Chrysler Jeep L4 2.5</p>
<p>248078</p> 	<ul style="list-style-type: none"> • 4.0" diameter • 5.1" height • 3/8" male o-ring inlet & outlet • Fuse plug • Sight glass 	<p>402498</p>	<p>Kysor/Westran</p>

Steel Receiver Dryers

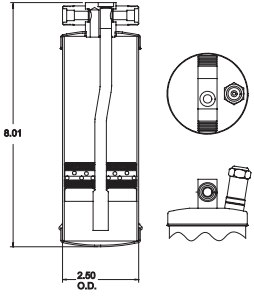
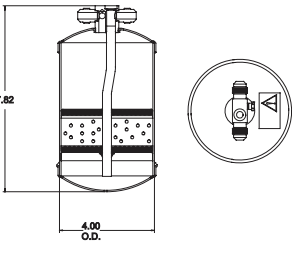
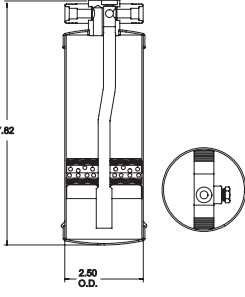
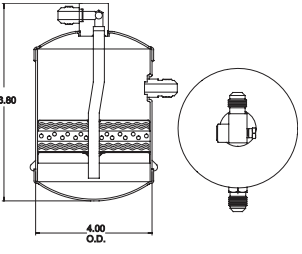
Illustration	Description	OEM No.	Application
<p>248085</p> 	<ul style="list-style-type: none"> • 2.5" diameter • 8.0" height • 3/8" male o-ring inlet & outlet • Sight glass • High pressure relief valve 	<p>402621</p> <p>1215020</p>	<p>Kysor/Westran</p> <p><u>Volvo</u> 81-87</p>
<p>248169</p> 	<ul style="list-style-type: none"> • 4.0" diameter • 7.8" height • 3/8" male flare inlet & outlet • Fuse plug • Sight glass 	<p>6P1309</p> <p>2-17948</p> <p>620206</p>	<p>Caterpillar</p> <p>Signet Systems</p> <p>Ford New Holland</p>
<p>248208-02</p> 	<ul style="list-style-type: none"> • 2.5" diameter • 7.8" height • 3/8" male o-ring inlet & outlet • Fuse plug • Sight glass 	<p>477820193</p>	<p>Volkswagen</p>
<p>248269</p> 	<ul style="list-style-type: none"> • 4.0" diameter • 6.8" height • 3/8" male side flare inlet • 3/8" male flare outlet • Fuse plug • Sight glass 	<p>111218C2</p>	<p>CNH</p>

Steel Receiver Dryers

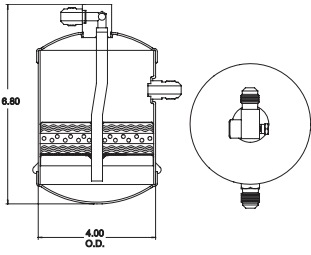
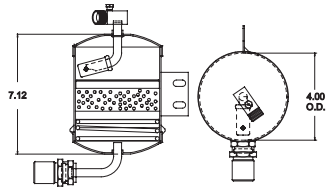
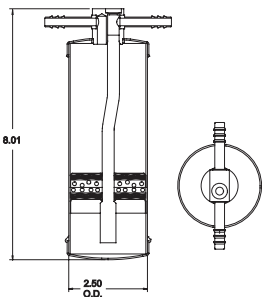
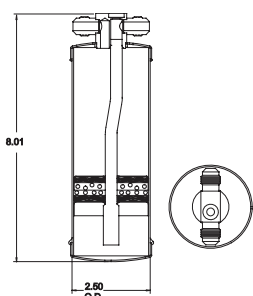
Illustration	Description	OEM No.	Application
<p>248278</p> 	<ul style="list-style-type: none"> • 4.0" diameter • 6.8" height • 3/8" male flare inlet & outlet • Fuse plug • Side sight glass 	<p>V30080</p>	<p>CNH</p>
<p>248293</p> 	<ul style="list-style-type: none"> • 4.0" diameter • 7.8" height • 3/8" male outlet • Male quick disconnect inlet • Fuse plug • Bracket 	<p>D6NN-19N644-B</p>	<p>Ford Tractor</p>
<p>249096</p> 	<ul style="list-style-type: none"> • 2.5" diameter • 8.0" height • 3/8" barb Inlet & outlet • Sight glass 	<p>1273002 1608 296-211-001 23-5020 04-00085 3-000328 83002 DOTZ-19959-A 402700 6144 7-0111 KAZ743-433 4-3931</p>	<p>ARA Clardy Coolaire/Nordic Danhard Evans/Temp Con Frigette Frigiquip Ford Light Truck 70-71 F100-250 (Acc. Air) Kysor/Westran RWC Industries Universal Truck Air Volkswagen Wynn's</p>
<p>249099</p> 	<ul style="list-style-type: none"> • 2.5" diameter • 8.0" height • 5/8" male flare inlet & outlet • Sight glass 	<p>12722000 6K9778 396-222-001-211-001 23-5010 18-00007 7-101 92-37094 83007 7979-402352 1618743-M91 4-3930 6106 7-0101 CCC43000002 24868-01-000 4-3930</p>	<p>ARA Caterpillar Coolaire/Nordic Danhard Evans/Temp Con Frigette Frigiking Frigiquip Mack Massey Ferguson Mazda 79-81 All RWC Industries Universal Truck Air Volkswagen Winnebago Wynn's</p>

Steel Receiver Dryers

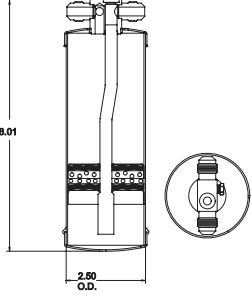
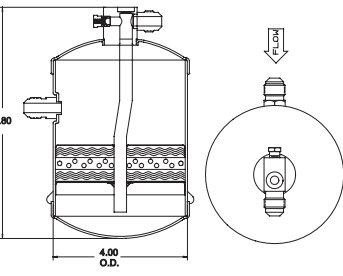
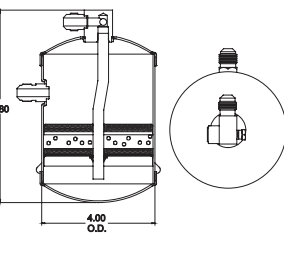
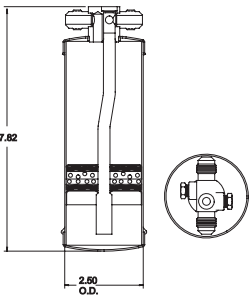
Illustration	Description	OEM No.	Application
<p>249172</p> 	<ul style="list-style-type: none"> • 2.5" diameter • 8.0" height • 3/8" male flare inlet & outlet • Fuse plug • Sight glass 	<p>1282803 396-222-003 033324 C9RZ-19959-A 10184462-M91 10184462-M91 1015A58G02 4-4059</p>	<p>ARA Coolaire/Nordic Excel Ford 71-73 Pinto Massey Ferguson Mercury 71-76 Capri ThermoKing Wynn's</p>
<p>249436</p> 	<ul style="list-style-type: none"> • 4.0" diameter • 8.0" height • 3/8" male flare inlet & outlet • Fuse plug • Sight glass 	<p>1143539 1162927 044044 77-22994 402000 402000 RD-5-4632-0</p>	<p>Allis Chalmers Excel Heston Kenworth 70-74 Kysor Unit #936005 Kysor/Westran Red Dot</p>
<p>249538</p> 	<ul style="list-style-type: none"> • 4.0" diameter • 6.8" height • 3/8" flare inlet • 3/8" flare outlet • Fuse plug • Side inlet • Side sight glass 	<p>044008 1-7282-5 8022147 63148-G1 539049-R1</p>	<p>Excel Full Vision Hesston Hupp International Harvester</p>
<p>249591</p> 	<ul style="list-style-type: none"> • 2.5" diameter • 6.8" height • 3/8" male flare inlet & outlet • Sight glass • Fuse plug • Two 1/8" NPT ports 	<p>7-334 ZVW251-433</p>	<p>Frigette Volkswagen</p>

Steel Receiver Dryers

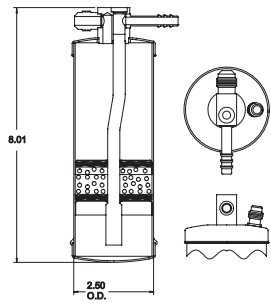
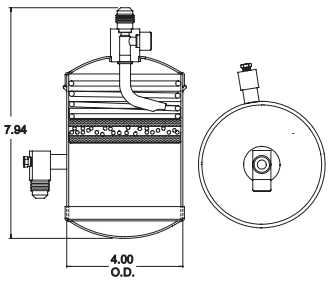
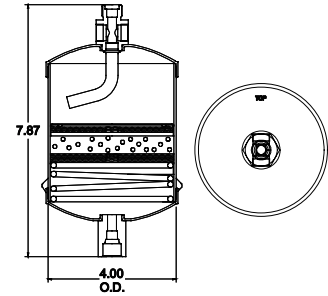
Illustration	Description	OEM No.	Application
<p>249620</p> 	<ul style="list-style-type: none"> • 2.5" diameter • 8.0" height • 3/8" male flare inlet • 3/8" barb outlet • 7/16" male flare port • Sight glass 	<p>25-195</p>	<p>Steiger Tractor</p>
<p>249634</p> 	<ul style="list-style-type: none"> • 4.0" diameter • 7.9" height • 3/8" male flare inlet & outlet • Fuse plug • Side sight glass 	<p>62786-G1 AH84591 3500-3 31-2750057</p>	<p>Hupp John Deere SGM White Farm</p>
<p>249755</p> 	<ul style="list-style-type: none"> • 4.0" diameter • 7.87" height • 3/8" female o-ring inlet • 3/8" male o-ring outlet • Dual sight glass on inlet 	<p>AC268464-02 066506-2750057 AR59780</p>	<p>Allis Chalmers Excel John Deere</p>

Parker Hannifin offers R-12 Calibrated Thermal Expansion Valves (TXVs)

Parker continues to manufacture R-12 valves due to the many vehicles still in operation today that have R-12 systems. The market continues to demand these valves in instances where freon can be recovered and reused cost effectively for minor repairs. Since these systems were designed to perform with an R-12 calibrated TXV, Parker recommends use of an R-12 valve when not retrofitting.

What are the differences between R-12 and R-134a?

R-134a is the current choice for automotive air conditioning due to its similar operating characteristics to R-12. However, R134a requires different lubricants than R-12 and has slightly different operating pressures. Parker R-12 TXVs are specifically designed and calibrated for the flow characteristics of R-12 refrigerant and lubricant.

Other manufacturers are offering R-134a calibrated TXVs that are adaptable to R-12 systems. In most cases this is an acceptable alternative. However, an R-134a valve in an R-12 system will reduce the flow of refrigerant and lubricants causing higher system temperatures. This may increase vent temperatures by a couple degrees and reduce compressor life.

If you choose not to retrofit, using an R-12 TXV is your best choice to insure the proper operation of the system.

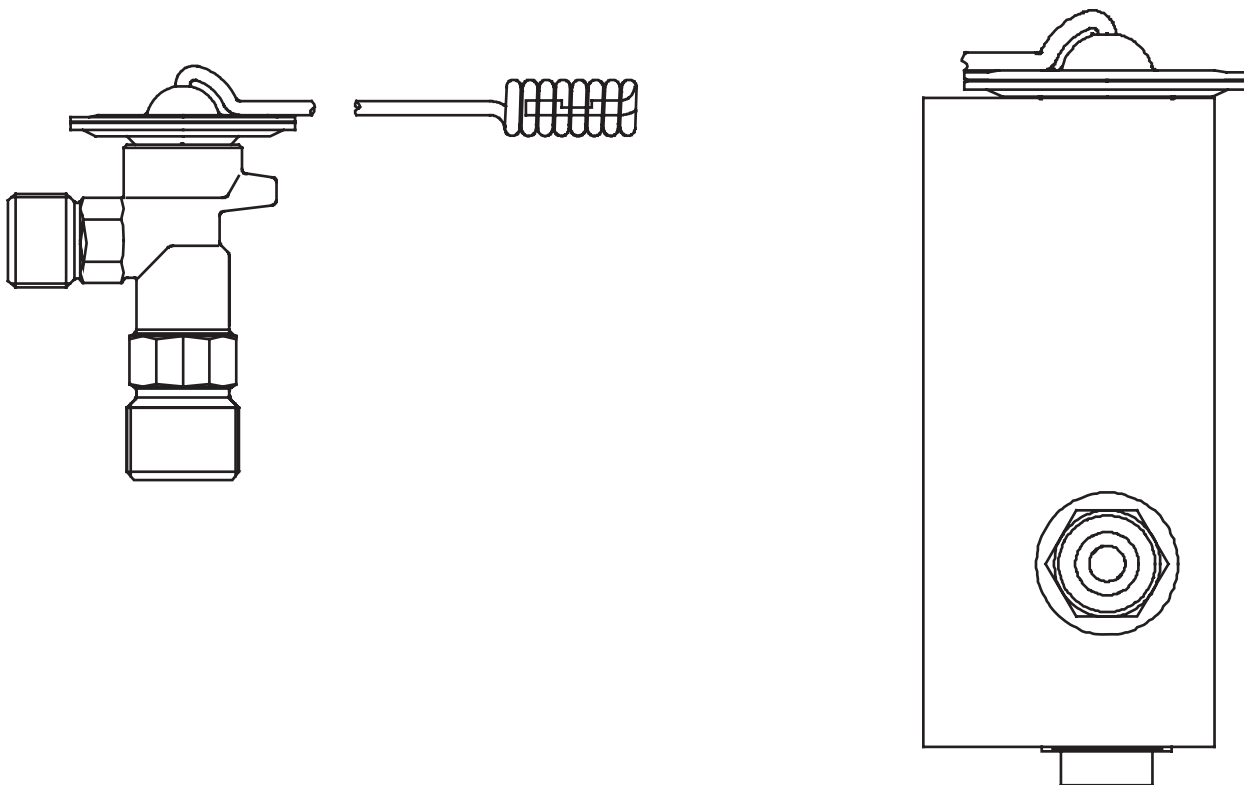

Automotive Expansion Valve Features

- Available in internal and externally equalized SAE flare and o-ring
- Balanced seat design provides precise control at any system load
- Meets IMACA Standard 301
- Rated air conditioning systems to 3 tons R-12
- Compact design



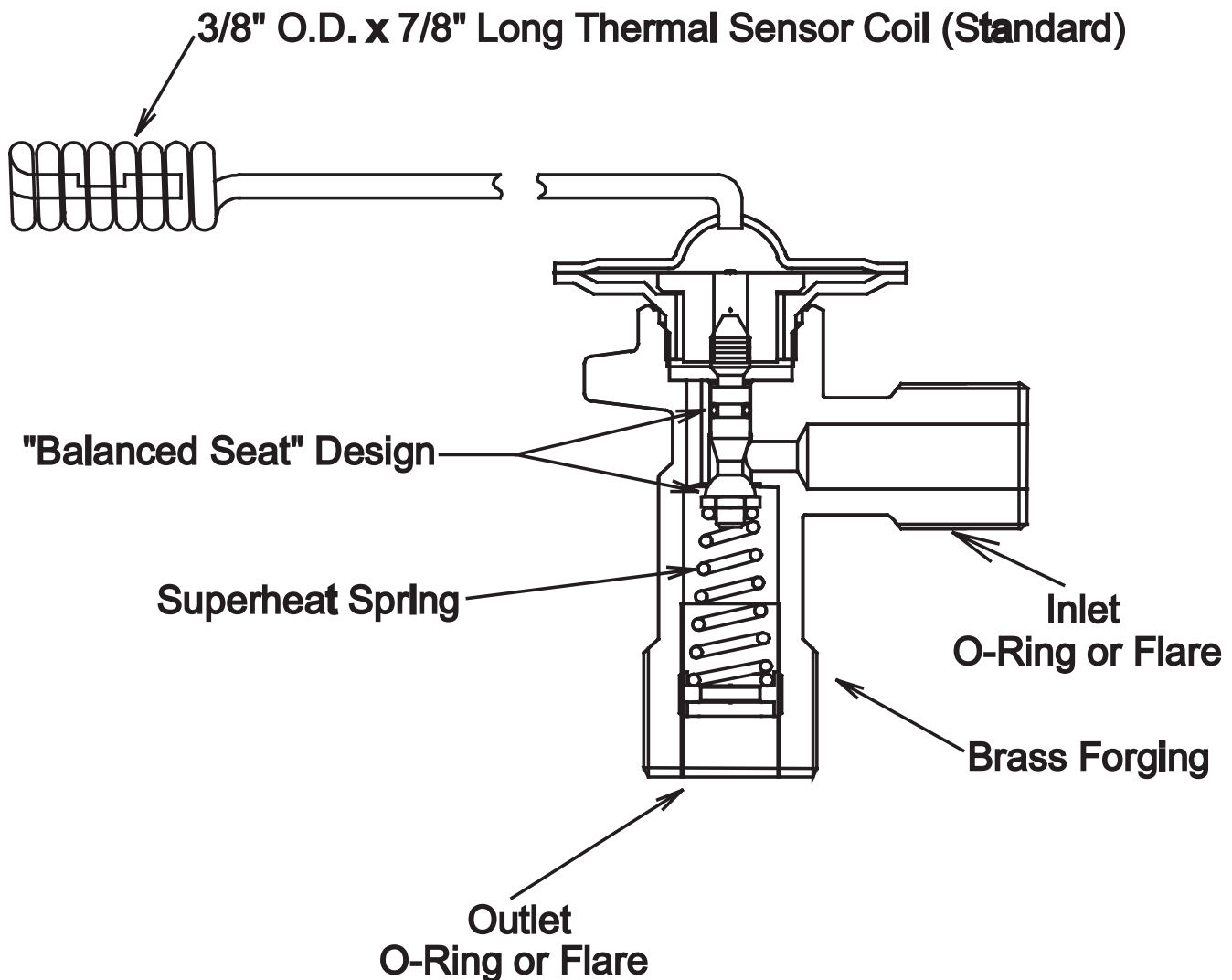

How to order:

Use series number pictured and specify superheat, MOP, length of cap tube and length of external equalizer tube. Parker will choose closest standard production models available.

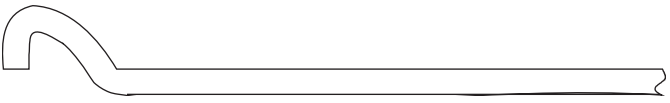

Automotive Expansion Valves

Bulb Types

<p>Coil</p> 	<p>Bulb</p> 	<p>3/8" Bulb</p> 
<p>Straight Cap</p> 	<p>Flat Bulb</p> 	

Equalizer Tube Fittings

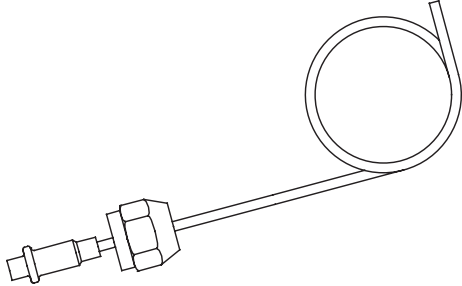
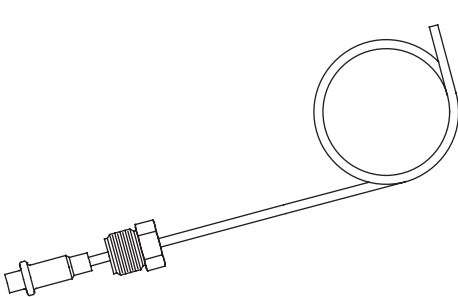
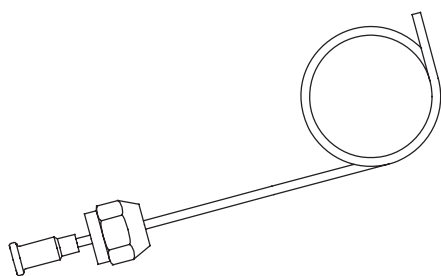
<p>1/4" O-Ring</p> 	<p>Inverted O-Ring</p> 	<p>1/4" Flare</p> 
--	---	---

Right Angle Expansion Valves

Internally Equalized - R12 Applications - Flare Fittings

Part. No.	Superheat (Degrees)	MOP	Cap Tube Length	Description	OE No.	OEM
030781-32	9	55	12 in.	<ul style="list-style-type: none"> • 1.5 ton capacity • Coil type • 3/8" male flare inlet • 1/2" male flare outlet • R12 application 	168903C1	CNH

Internally Equalized - R12 Applications - O-Ring Fittings

Part. No.	Superheat (Degrees)	MOP	Cap Tube Length	Description	OE No.	OEM
031249-41	9	55	20 in.	<ul style="list-style-type: none"> • 1.5 ton capacity • Coil type • 3/8" male o-ring inlet • 1/2" male o-ring outlet • R12 application 	--	--
031249-64	10	Liquid	4.9 in. Prebent	<ul style="list-style-type: none"> • 1.5 ton capacity • Bulb type • 3/8" male o-ring inlet • 1/2" male o-ring outlet • R12 application 	F2UZ 19849 AA	Ford
031249-67	9	55	16.5 in.	<ul style="list-style-type: none"> • 2.0 ton capacity • Straight type bulb • M16 Male O-ring • M20 Male O-ring • R12 Application 	52459768	91-95 GM
031249-68	9	55	8 in.	<ul style="list-style-type: none"> • 2.0 ton capacity • Straight type bulb • M16 Male O-ring • M20 Male O-ring • R12 Application 	52456661	GM

Externally Equalized - R12 Applications - Flare Fittings

Part. No.	Superheat (Degrees)	MOP	Cap Tube Length	Description	OE No.	OEM
031130-01	9	45	12 in.	<ul style="list-style-type: none"> • 2.0 ton capacity • Coil bulb type • 3/8" male flare inlet • 1/2" male flare outlet • 16" equalizer length • 1/4" flare nut equalizer • R12 application 	66398C1	CNH
031130-12	9	65	10 in.	<ul style="list-style-type: none"> • 2.0 ton capacity • Coil bulb type • 3/8" male flare inlet • 1/2" male flare outlet • 12.5" equalizer length • 1/4" flare nut • R12 application 	--	--

Externally Equalized - R12 Applications - Flare Fittings

Part. No.	Superheat (Degrees)	MOP	Cap Tube Length	Description	OE No.	OEM
031130-29	9	55	18 in.	<ul style="list-style-type: none"> • 1.5 ton capacity • Coil bulb type • 3/8" male flare inlet • 1/2" male flare outlet • 18" equalizer length • 1/4" flare nut • R12 application 	--	--
031130-41	10	62	7 in.	<ul style="list-style-type: none"> • 2.0 ton capacity • Bulb type • 3/8" male flare inlet • 1/2" male flare outlet • 8" equalizer length • 1/4" flare nut • R12 application 	F64389	CNH
031130-55	10	Liquid	12 in.	<ul style="list-style-type: none"> • 2.5 ton capacity • Bulb type • 3/8" male flare inlet • 1/2" male flare outlet • 12" equalizer length • R12 application 	1P6526	Caterpillar

Externally Equalized - R12 Applications - O-Ring Fittings

Part. No.	Superheat (Degrees)	MOP	Cap Tube Length	Description	OE No.	OEM
031131-02	9	55	12.0	<ul style="list-style-type: none"> • 1.5 ton capacity • Coil type bulb • 3/8" male o-ring inlet • 1/2" male o-ring outlet • 16.0" equalizer length • 1/4" female o-ring equalizer type • R12 application 	2G-0401	Caterpillar
031131-19	10	60	33.0	<ul style="list-style-type: none"> • 2.0 ton capacity • Flat bulb type • 3/8" male o-ring inlet • 1/2" male o-ring outlet • 33.0" equalizer length • 1/4" male O-ring equalizer type • R12 Application 	--	--
031131-87	9	55	20.0	<ul style="list-style-type: none"> • 1.5 ton capacity • Coil bulb type • 3/8" male o-ring inlet • 1/2" male o-ring outlet • 16.5" equalizer length • 1/4" female O-ring equalizer type • R12 application 	--	--
031134-154	12	55	30.0	<ul style="list-style-type: none"> • 1.5 ton capacity • Coil bulb type • 3/8" male o-ring inlet • 1/2" male o-ring outlet • 18" equalizer length • 1/4" male flare equalizer type • R12 application 	12491237 AH20468	General Motors John Deere

Internally Equalized - 134a Applications - O-Ring Fittings

Part. No.	Superheat (Degrees)	MOP	Cap Tube Length	Description	OE No.	OEM
031134-02	5	65	7.0 in.	<ul style="list-style-type: none"> • 2.0 ton capacity • Coil type bulb • 3/8" male o-ring inlet • 1/2" male o-ring outlet • 134a application 	--	--
031134-03	8	55	12 in.	<ul style="list-style-type: none"> • 2.0 ton capacity • Coil type bulb • 3/8" male o-ring inlet • 1/2" male o-ring outlet • 134a application 	--	--
031134-04	10	Liquid	5.0 in.	<ul style="list-style-type: none"> • 1.5 ton capacity • 1/2" bulb type • 3/8" male o-ring inlet • 1/2" male o-ring outlet • 134a application 	F4UH 19849 AA	Ford
031134-08	4.5	55	8.0 in.	<ul style="list-style-type: none"> • 2.0 ton capacity • Straight bulb type • M 16 male o-ring inlet • M 20 male o-ring outlet • 134a application • w/inlet screen 	52459601	GM
031134-09	4.5	11	11.5 in.	<ul style="list-style-type: none"> • 2.0 ton capacity • Straight bulb type • M 16 male o-ring inlet • M 20 male o-ring outlet • 134a application • w/inlet screen 	52459602	GM
031134-10	5	55	10.0 in.	<ul style="list-style-type: none"> • 2.0 ton capacity • Coil bulb type • 3/8" male o-ring inlet • 1/2" male o-ring outlet • 134a application 	--	--
031134-20	8	55	24 in.	<ul style="list-style-type: none"> • 1.5 ton capacity • Coil bulb type • 3/8" male o-ring inlet • 1/2" male o-ring outlet • 134a application 	--	--
031134-23	8	65	8 in.	<ul style="list-style-type: none"> • 2.0 ton capacity • Coil bulb type • 3/8" male o-ring inlet • 1/2" male o-ring outlet • 134a application 	--	--
031134-25	12	55	16.5 in.	<ul style="list-style-type: none"> • 1.5 ton capacity • Straight bulb type • M 16 male o-ring inlet • M 20 male o-ring outlet • 134a application 	RD-5-10734-0 5X0103430000	Red Dot Modine
031134-27	8	Liquid	8.0 in.	<ul style="list-style-type: none"> • 2.0 ton capacity • Bulb type • 3/8" male o-ring inlet • 1/2" male o-ring outlet • 134a application 	3038920M91	Agco

Internally Equalized - 134a Applications - O-Ring Fittings

Part. No.	Superheat (Degrees)	MOP	Cap Tube Length	Description	OE No.	OEM
031134-32	5	60	12 in.	<ul style="list-style-type: none"> • 2.0 ton capacity • Coil type bulb • 3/8" male o-ring inlet • 1/2" male o-ring outlet • 134a application 	--	--
031134-34	8	Liquid	19 in.	<ul style="list-style-type: none"> • 1.5 ton capacity • Bulb type • 3/8" male o-ring inlet • 1/2" male o-ring outlet • 134a application 	--	--
031134-41	7	29.5	Prebent	<ul style="list-style-type: none"> • 2.0 ton capacity • Bulb type • 3/8" male o-ring inlet • 1/2" male o-ring outlet • 134a application 	XF5Z 19849 AA	Ford
031134-42	7	70	11.5 in.	<ul style="list-style-type: none"> • 2.0 ton capacity • Straight type • M16 male o-ring inlet • M20 male o-ring outlet • 134a application • w/inlet screen 	52481625	Delphi Thermal
031134-50	9	55	16.5 in.	<ul style="list-style-type: none"> • 2.0 ton capacity • Bulb type • 3/8" male o-ring inlet • 1/2" male o-ring outlet • 134a application w/inlet screen • w/inlet screen 	88959387	General Motors
031134-207	8	55	12.0 in.	<ul style="list-style-type: none"> • 1.5 ton capacity • Coil type bulb • 3/8" male o-ring inlet • 1/2" male o-ring outlet • 134a application 	--	--
031134-402	10	Liquid	5.4 in prebent	<ul style="list-style-type: none"> • 1.5 ton capacity • Bulb type • 3/8" male o-ring inlet • 1/2" male o-ring outlet • 134a application, with by-pass bleed 	YF2Z 19849 AA	Ford
031134-403	10	Liquid	5.4 in. prebent	<ul style="list-style-type: none"> • 1.5 ton capacity • Bulb type • 3/8" male o-ring inlet • 1/2" male o-ring outlet • 134a application 	2L2H-19849-CA	Ford
031134-405	10	Liquid	5.4 in. prebent	<ul style="list-style-type: none"> • 1.5 ton capacity • Bulb type • 3/8" male o-ring inlet • 1/2" male o-ring outlet • 134a application 	VP6L2H 19849 BA	Ford

Externally Equalized - 134a Applications - O-Ring Fittings

Part. No.	Superheat (Degrees)	MOP	Cap Tube Length	Description	OE No.	OEM
031134-115	16	65	12 in.	<ul style="list-style-type: none"> • 1.5 ton capacity • 1/2" bulb type • 3/8" male o-ring inlet • 1/2" male o-ring outlet • 13" equalizer length • 1/4" male o-ring equalizer type • 134a application 	86531348	CNH
031134-116	10.5	65	33.0	<ul style="list-style-type: none"> • 2.0 ton capacity • 3/8" bulb type • 3/8" male o-ring inlet • 1/2" male o-ring outlet • 33" equalizer length • 1/4" male o-ring equalizer type • 134a application 	--	--
031134-117	8	65	14.0	<ul style="list-style-type: none"> • 2.0 ton capacity • Coil type • 3/8" male o-ring inlet • 1/2" male o-ring outlet • 12" equalizer length • 1/4" female o-ring equalizer type • 134a application 	--	--
031134-118	7	65	12 in.	<ul style="list-style-type: none"> • 2.0 ton capacity • Coil type • 3/8" male o-ring inlet • 1/2" male o-ring outlet • 16" equalizer length • 1/4" female o-ring equalizer type • 134a application 	1280333C2	CNH
031134-120	12	55	30.0	<ul style="list-style-type: none"> • 1.5 ton capacity • Coil type • 3/8" male o-ring inlet • 1/2" male o-ring outlet • 18" equalizer length • 1/4" male o-ring equalizer type • 134a application 	--	--
031134-129	8	55	12.0 in.	<ul style="list-style-type: none"> • 1.5 ton capacity • Coil type bulb • 3/8" male o-ring inlet • 1/2" male o-ring outlet • 13" equalizer length • 1/4" male o-ring equalizer type • 134a application 	--	--
031134-137	5	55	20 in.	<ul style="list-style-type: none"> • 1.5 ton capacity • Coil type bulb • 3/8" male o-ring inlet • 1/2" male o-ring outlet • 16.34" equalizer length • 1/4" female o-ring equalizer type • 134a application 	--	--

Externally Equalized - 134a Applications - O-ring Fittings

Part. No.	Superheat (Degrees)	MOP	Cap Tube Length	Description	OE No.	OEM
031134-138	8	55	14 in.	<ul style="list-style-type: none"> • 2.0 ton capacity • Coil type bulb • 3/8" male o-ring inlet • 1/2" male o-ring outlet • 16.0" equalizer length • 1/4" female o-ring equalizer type • 134a application 	404292	Kysor
031134-152	8	55	15.3 in.	<ul style="list-style-type: none"> • 4 ton capacity (with bypass) • Bulb type • 3/8" male o-ring inlet • 1/2" male o-ring outlet • 12.0" equalizer length • 1/4" female o-ring equalizer type • 134a application 	--	--
031134-157	5	55	8.0 in.	<ul style="list-style-type: none"> • 2.0 ton capacity • Bulb type • 3/8" male o-ring inlet • 1/2" male o-ring outlet • 9.5" equalizer length • 1/4" female o-ring equalizer type • 134a application 	RE206757	John Deere

Externally Equalized - 134a Applications - Flare Fittings

Part. No.	Superheat (Degrees)	MOP	Cap Tube Length	Description	OE No.	OEM
031134-300	10	55	12.0 in.	<ul style="list-style-type: none"> • 2.5 ton capacity • Coil type • 3/8" male flare inlet & outlet • 12.0" equalizer length • 1/4" flare nut equalizer type • 134a application 	--	--
031134-305	7.5	55	18 in.	<ul style="list-style-type: none"> • 1.5 ton capacity • Coil type • 3/8" male flare inlet & outlet • 18.0" equalizer length • 1/4" flare nut equalizer type • 134a application 	--	--
031134-309	9	60	30	<ul style="list-style-type: none"> • 2.0 ton capacity • Coil type • 3/8" male flare inlet & outlet • 18.0" equalizer length • 1/4" flare nut equalizer type • 134a application 	--	--
031134-312	7.5	55	19 in.	<ul style="list-style-type: none"> • 1.5 ton capacity • Coil type • 3/8" male flare inlet & outlet • 31.0" equalizer length • 1/4" flare nut equalizer type • 134a application 	--	--

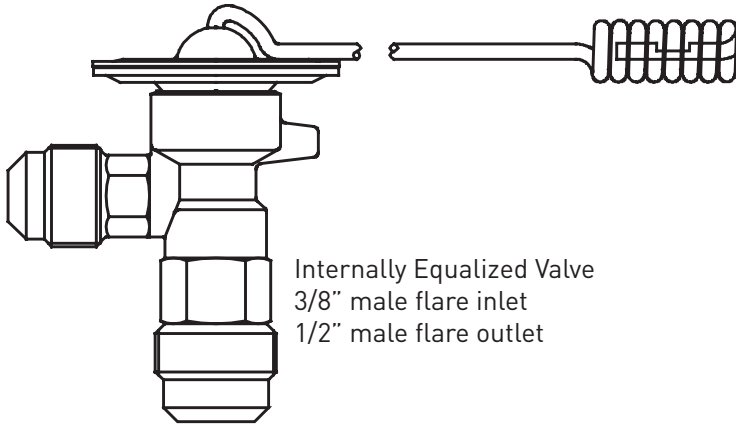

Internally Equalized Valve
3/8" male flare inlet
1/2" male flare outlet

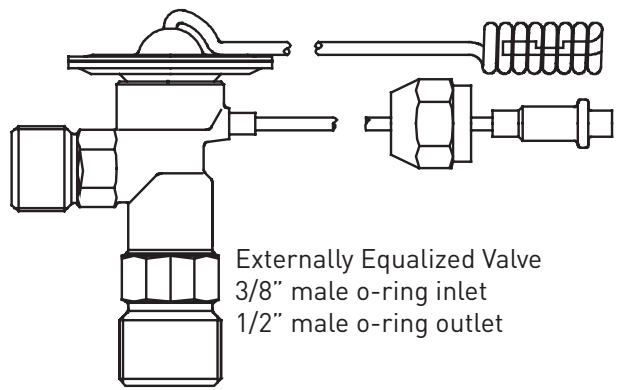

Externally Equalized Valve
3/8" male o-ring inlet
1/2" male o-ring outlet

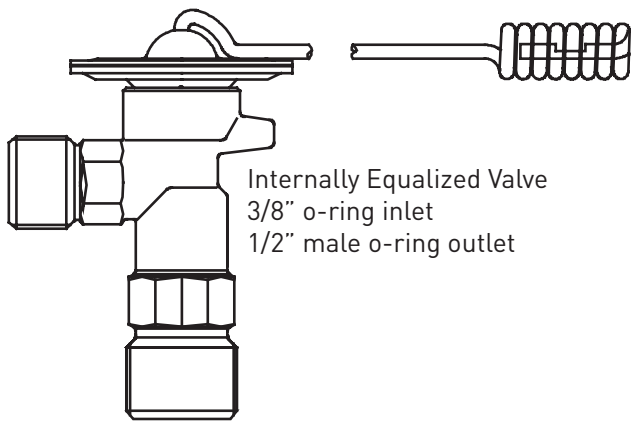

Internally Equalized Valve
3/8" o-ring inlet
1/2" male o-ring outlet

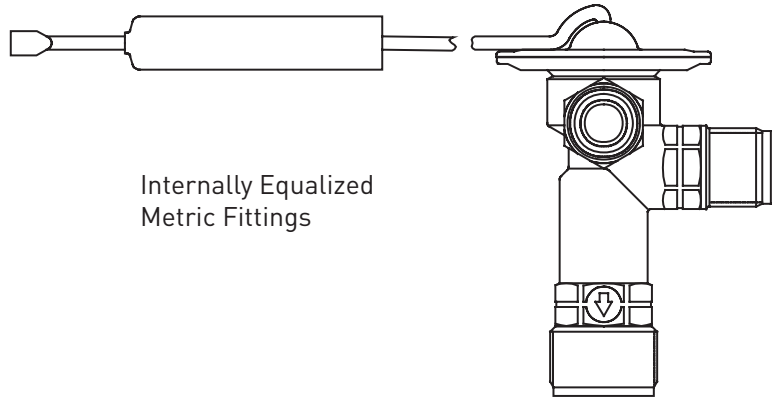

Internally Equalized
Metric Fittings

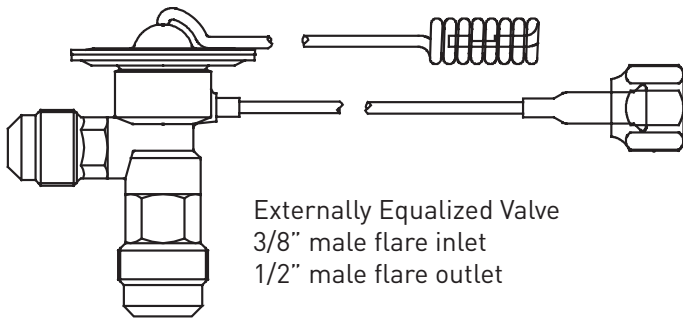

Externally Equalized Valve
3/8" male flare inlet
1/2" male flare outlet

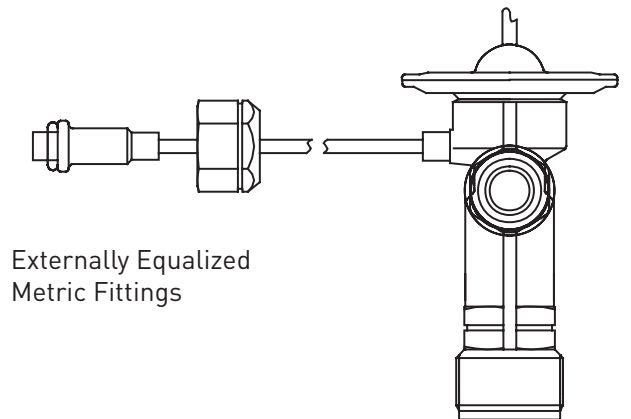

Externally Equalized
Metric Fittings

Bulbless or Block Expansion Valves

Function

The Bulbless Expansion Valve or Block Valve provides superheat control via 4-port adaptation to the refrigeration system eliminating bulb and external equalizer lines.

Features:

- Proper superheat control regardless of coil pressure drop
- Rated at 2 tons R-12 and R-134a
- Anti-hunt power element isolation
- Anodized aluminum body and stainless steel power element
- Chrysler style flange connections
- Ships with plug and o-ring for Chrysler LPCO switch

Block Style Valves

040138-100s and 329- Series

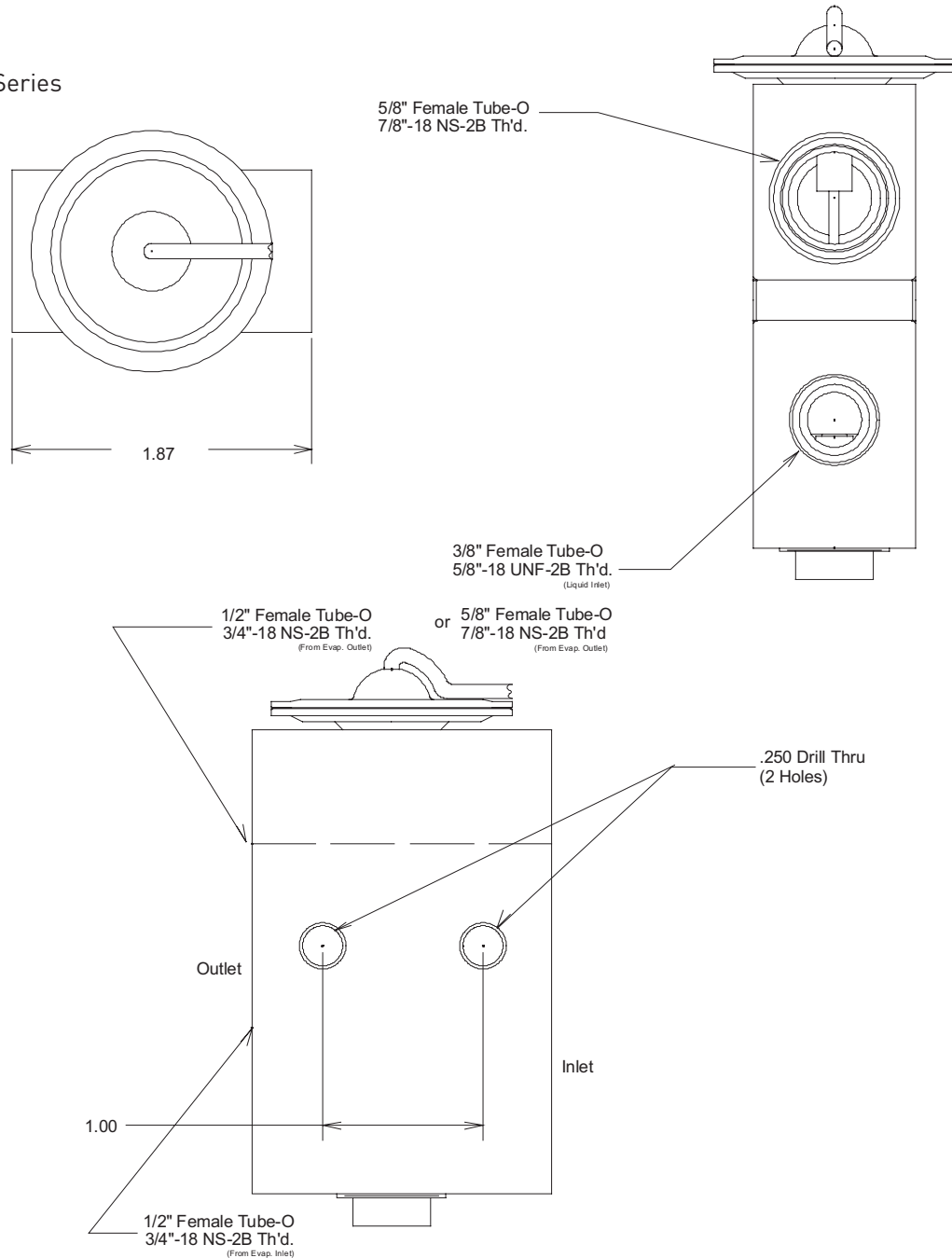

Block Valves

529- Series

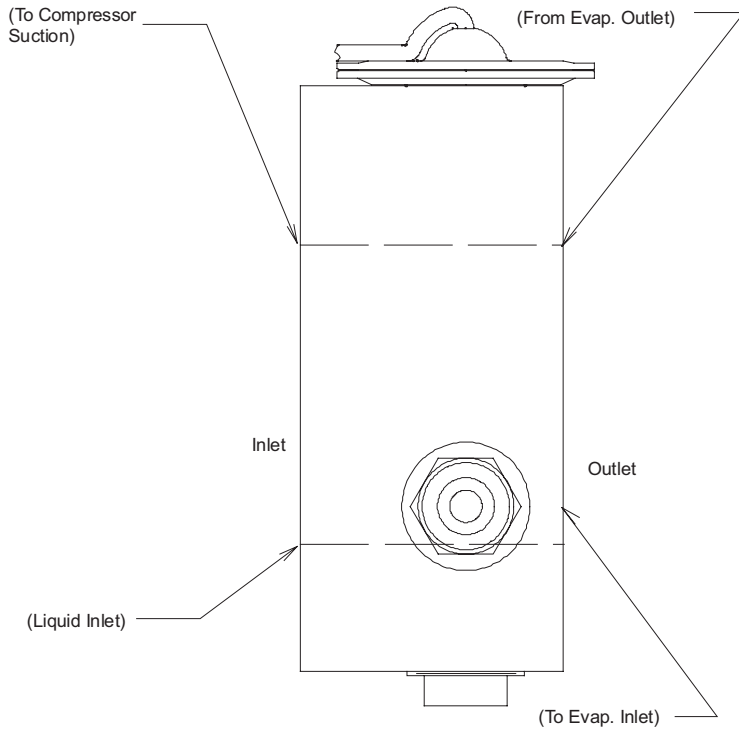
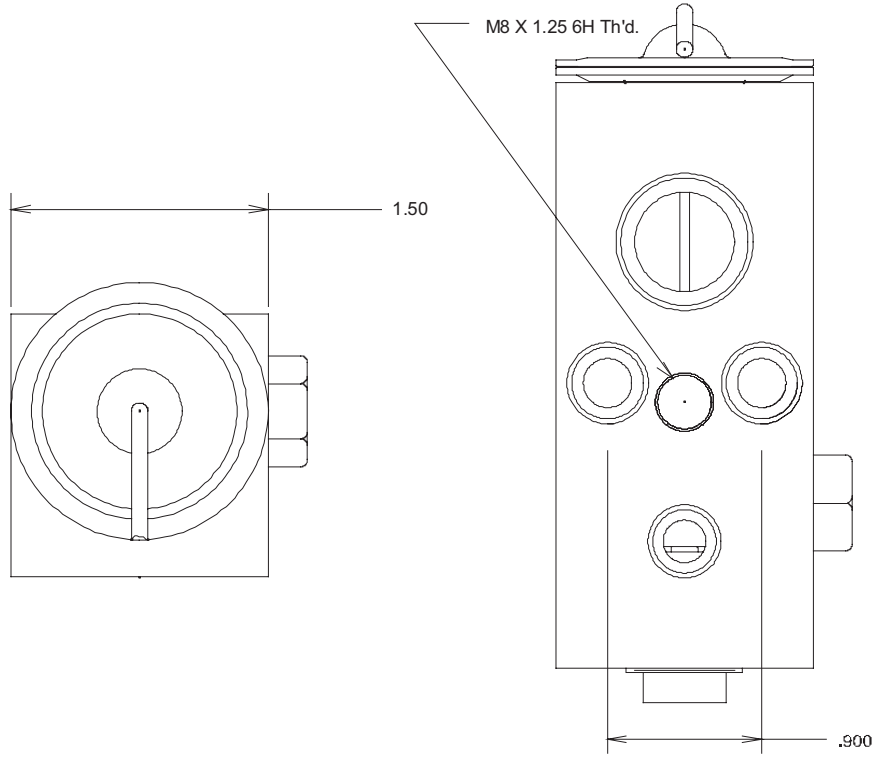

Block Valves

929- Series

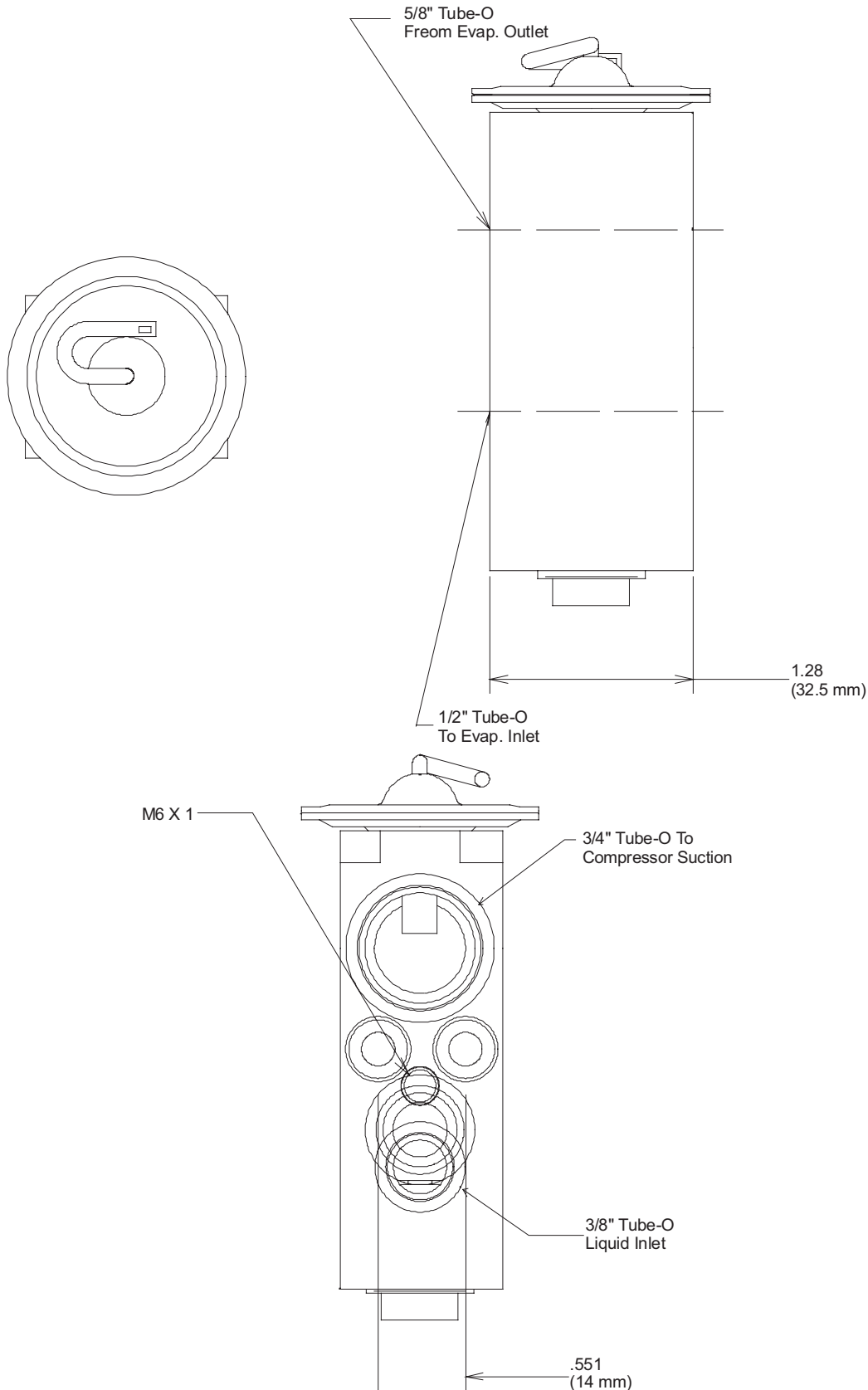

Block Valves

Part. No.	Superheat (Degrees)	MOP	Tonnage	Connections	Misc.	OE No.	OEM
040138-107	9	50	2.0	<ul style="list-style-type: none"> • 3/8" liquid inlet • 1/2" evaporator inlet • 1/2" evaporator outlet • 5/8" outlet to compressor 	134a application	3V-0258 12356573	Caterpillar GM
040138-115	9	65	2.0	<ul style="list-style-type: none"> • 3/8" liquid inlet • 1/2" evaporator inlet • 1/2" evaporator outlet • 5/8" outlet to compressor 	134a application	118321C1	CNH
040138-123	8	50	2.0	<ul style="list-style-type: none"> • 3/8" liquid inlet • 1/2" evaporator inlet • 1/2" evaporator outlet • 5/8" outlet to compressor 	134a application	--	--
040138-125	7	80	2.0	<ul style="list-style-type: none"> • 3/8" liquid inlet • 1/2" evaporator inlet • 1/2" evaporator outlet • 5/8" outlet to compressor 	134a application	--	--
040138-129	5	55	2.0	<ul style="list-style-type: none"> • 3/8" liquid inlet • 1/2" evaporator inlet • 1/2" evaporator outlet • 5/8" outlet to compressor 	134a application	--	--
040138-132	5	50	2.0	<ul style="list-style-type: none"> • 3/8" liquid inlet • 1/2" evaporator inlet • 1/2" evaporator outlet • 5/8" outlet to compressor 	134a application	--	--
040138-136	5	50	2.0	<ul style="list-style-type: none"> • 3/8" liquid inlet • 1/2" evaporator inlet • 5/8" evaporator outlet • 5/8" outlet to compressor 	134a application	AH203871	John Deere
040138-142	5	50	1.5	<ul style="list-style-type: none"> • 3/8" liquid inlet • 1/2" evaporator inlet • 5/8" evaporator outlet • 5/8" outlet to compressor 	134a application, with bypass	A22-45432-001	Freightliner
040138-143	8	50	2.0	<ul style="list-style-type: none"> • 3/8" liquid inlet • 1/2" evaporator inlet • 1/2" evaporator outlet • 5/8" outlet to compressor 	134a application	6A10725G01	ThermoKing
040138-144	8	50	2.0	<ul style="list-style-type: none"> • 3/8" liquid inlet • 1/2" evaporator inlet • 5/8" evaporator outlet • 5/8" outlet to compressor 	134a application	--	--
040138-146	5	70	2.0	<ul style="list-style-type: none"> • 3/8" liquid inlet • 1/2" evaporator inlet • 5/8" evaporator outlet • 5/8" outlet to compressor 	134a application	--	Bergstrom
040138-152	6	70	2.0	<ul style="list-style-type: none"> • 3/8" liquid inlet • 1/2" evaporator inlet • 5/8" evaporator outlet • 5/8" outlet to compressor 	134a application	386535A1	CNH
040138-153a	10	70	1.5	<ul style="list-style-type: none"> • 3/8" liquid inlet • 1/2" evaporator inlet • 5/8" evaporator outlet • 5/8" outlet to compressor 	134a application, with bypass	1C3H 19849 AA	Ford

Block Valves

Part. No.	Superheat (Degrees)	MOP	Tonnage	Connections	Misc.	OE No.	OEM
040138-155	10	70	1.5	<ul style="list-style-type: none"> • 3/8" liquid inlet • 1/2" evaporator inlet • 5/8" evaporator outlet • 5/8" outlet to compressor 	134a application	F4XY 19849 A	Ford
040138-159a	15	70	2.0	<ul style="list-style-type: none"> • 3/8" liquid inlet • 1/2" evaporator inlet • 5/8" evaporator outlet • 5/8" outlet to compressor 	134a application, with bypass	2L1H 19849 BB	Ford
040138-210a	2	57	1.75	<ul style="list-style-type: none"> • 1/2" liquid inlet • 1/2" evaporator inlet • 3/4" evaporator outlet • 3/4" outlet to compressor 	134a application, w/ cross charge	55056025AE	2001 Dodge Durango V-8
040138-301	0	55	2.0	<ul style="list-style-type: none"> • 3/8" liquid inlet • 1/2" evaporator inlet • 5/8" evaporator outlet • 3/4" outlet to compressor 	134a application , with special charge	52464384	GM
040138-329a	7	55	1.75	<ul style="list-style-type: none"> • 3/8" liquid inlet • 1/2" evaporator inlet • 3/4" evaporator outlet • 3/4" outlet to compressor 	134a application, w/ cross charge and bypass	04885974AD	Chrysler
040138-330a	12	70	1.0	<ul style="list-style-type: none"> • 10 Denso o-ring liquid inlet • 15 Denso o-ring evaporator inlet • 15 Denso o-ring evaporator outlet • 18 Denso o-ring outlet to compressor 	134a application, with bypass	--	Chrysler 99-03 Durango Aux unit
040138-333a	5	57	1.75	<ul style="list-style-type: none"> • 1/2" liquid inlet • 1/2" evaporator inlet • 3/4 evaporator outlet • 3/4" outlet to compressor 	134a application, cross charge, bypass, stud	05061342AD	2005 Chrysler
040138-334a	23	60	1.0	<ul style="list-style-type: none"> • 10 Denso o-ring liquid inlet • 15 Denso o-ring evaporator inlet • 15 Denso o-ring evaporator outlet • 18 Denso o-ring outlet to compressor 	134a application, bypass	G9477	Chrysler
040138-342	5.5	57	1.75	<ul style="list-style-type: none"> • 1/2" liquid inlet • 1/2" evaporator inlet • 3/4 evaporator outlet • 3/4" outlet to compressor 	134a application, bypass, cross charge, stud	05061342AD	Chrysler
040138-401a	10	65	1.5	<ul style="list-style-type: none"> • 3/8" slimline liquid inlet • 1/2" slimline evaporator inlet • 5/8" slimline evaporator outlet • 5/8" slimline outlet to compressor 	134a application, with bypass	644016.02 (main unit)	Freightliner

Block Valves

Part. No.	Superheat (Degrees)	MOP	Tonnage	Connections	Misc.	OE No.	OEM
040138-402	5	65	1.5	<ul style="list-style-type: none"> • 3/8" slimline liquid inlet • 1/2" slimline evaporator inlet • 5/8" slimline evaporator outlet • 5/8" slimline outlet to compressor 	134a application	6440127.02 (aux unit)	Freightliner
040138-403	12	50	1.5	<ul style="list-style-type: none"> • 3/8" slimline liquid inlet • 1/2" slimline evaporator inlet • 5/8" slimline evaporator outlet • 5/8" slimline outlet to compressor 	134a application	--	Freightliner
040138-404a	-2	65	1.0	<ul style="list-style-type: none"> • 3/8" slimline liquid inlet • 1/2" slimline evaporator inlet • 5/8" slimline evaporator outlet • 5/8" slimline outlet to compressor 	134a application, cross charge	--	Freightliner
329-403	5	53.5	2.0	<ul style="list-style-type: none"> • 3/8" liquid inlet • 1/2" evaporator inlet • 5/8" evaporator outlet • 5/8" outlet to compressor 	134a application	AH 203871	John Deere
329-404	8	53.5	1.5	<ul style="list-style-type: none"> • 3/8" liquid inlet • 1/2" evaporator inlet • 1/2" evaporator outlet • 5/8" outlet to compressor 	134a application	--	--
329-406	5	53.5	1.5	<ul style="list-style-type: none"> • 3/8" liquid inlet • 1/2" evaporator inlet • 1/2" evaporator outlet • 5/8" outlet to compressor 	134a application	--	--
329-408	8	53.5	2.0	<ul style="list-style-type: none"> • 3/8" liquid inlet • 1/2" evaporator inlet • 1/2" evaporator outlet • 5/8" outlet to compressor 	134a application, 7/16" gage port	09827056	CNH
329-415	5	53.5	2.0	<ul style="list-style-type: none"> • 3/8" liquid inlet • 1/2" evaporator inlet • 1/2" evaporator outlet • 5/8" outlet to compressor 	134a application	9705763	CNH
329-431	5	53.5	2.0	<ul style="list-style-type: none"> • 3/8" liquid inlet • 1/2" evaporator inlet • 5/8" evaporator outlet • 5/8" outlet to compressor 	134a application	EA1075	Paccar
329-439	5	53.5	1.5	<ul style="list-style-type: none"> • 3/8" liquid inlet • 1/2" evaporator inlet • 1/2" evaporator outlet • 5/8" outlet to compressor 	134a application	4443017	88-89 Dodge Ram 50
329-440	5	53.5	1.5	<ul style="list-style-type: none"> • 3/8" liquid inlet • 1/2" evaporator inlet • 1/2" evaporator outlet • 5/8" outlet to compressor 	134a application	--	Red Dot / Modine

Block Valves

Part. No.	Superheat (Degrees)	MOP	Tonnage	Connections	Misc.	OE No.	OEM
329-444	5	53.5	1.5	<ul style="list-style-type: none"> • 3/8" liquid inlet • 1/2" evaporator inlet • 1/2" evaporator outlet • 5/8" outlet to compressor 	134a application	--	Behr
329-456	5	50	1.5	<ul style="list-style-type: none"> • 3/8" liquid inlet • 1/2" evaporator inlet • 5/8" evaporator outlet • 5/8" outlet to compressor 	134a application	EA1260	Paccar
329-465	8	53.5	1.5	<ul style="list-style-type: none"> • 3/8" liquid inlet • 1/2" evaporator inlet • 5/8" evaporator outlet • 5/8" outlet to compressor 	134a application	55037271	Chrysler
329-468	8	53.5	1.5	<ul style="list-style-type: none"> • 3/8" liquid inlet • 1/2" evaporator inlet • 5/8" evaporator outlet • 5/8" outlet to compressor 	134a application	--	--
329-470	5	53.5	2.0	<ul style="list-style-type: none"> • 3/8" liquid inlet • 1/2" evaporator inlet • 1/2" evaporator outlet • 5/8" outlet to compressor 	134a application, M10 gage port	--	Red Dot
329-474	5	50	1.5	<ul style="list-style-type: none"> • 3/8" liquid inlet • 1/2" evaporator inlet • 1/2" evaporator outlet • 5/8" outlet to compressor 	134a application, with bypass	--	Behr / Bergstrom
329-477	5	50	1.5	<ul style="list-style-type: none"> • 3/8" liquid inlet • 1/2" evaporator inlet • 5/8" evaporator outlet • 5/8" outlet to compressor 	134a application	--	Red Dot
329-481	5	53.5	2.0	<ul style="list-style-type: none"> • 3/8" liquid inlet • 1/2" evaporator inlet • 5/8" evaporator outlet • 5/8" outlet to compressor 	134a application	--	Red Dot
329a-435	5	53.5	2.0	<ul style="list-style-type: none"> • 3/8" liquid inlet • 1/2" evaporator inlet • 1/2" evaporator outlet • 5/8" outlet to compressor 	134a application	--	--
329a-436	8	53.5	2.0	<ul style="list-style-type: none"> • 3/8" liquid inlet • 1/2" evaporator inlet • 1/2" evaporator outlet • 5/8" outlet to compressor 	134a application	--	--
329a-441	5	50	2.0	<ul style="list-style-type: none"> • 3/8" liquid inlet • 1/2" evaporator inlet • 5/8" evaporator outlet • 5/8" outlet to compressor 	134a application	--	--

Block Valves

Part. No.	Superheat (Degrees)	MOP	Tonnage	Connections	Misc.	OE No.	OEM
529-411	13.5	62	2.0	<ul style="list-style-type: none"> • 3/8" FLSC liquid inlet • 1/2" Chrysler pilot bushing evaporator inlet • 3/4" Chrysler pilot bushing evaporator outlet • 5/8" FSLC outlet to compressor 	134a application	04596192	95-00 Chrysler Cirrus, 96-00 Chrysler Sebring, Dodge Intrepid
529-421	6.5	62	1.5	<ul style="list-style-type: none"> • 3/8" deep Chrysler flange liquid inlet • 1/2" Chrysler flange evaporator inlet • 3/4" Chrysler flange evaporator outlet • 3/4" deep Chrysler flange outlet to compressor 	134a application, LP Switch, Cold Control	04677334	94-95 Caravan / Voyager/ Town & Country
529-430	6.5	62	1.5	<ul style="list-style-type: none"> • 3/8" deep Chrysler flange liquid inlet • 1/2" Chrysler flange evaporator inlet • 3/4" Chrysler flange evaporator outlet • 3/4" deep Chrysler flange outlet to compressor 	134a application, 3/8" female port with plug	04796557	Chrysler
529-431	6.5	62	1.5	<ul style="list-style-type: none"> • 3/8" deep Chrysler flange liquid inlet • 1/2" Chrysler flange evaporator inlet • 3/4" Chrysler flange evaporator outlet • 3/4" deep Chrysler flange outlet to compressor 	134a application, 3/8" female port with plug	04796893	Chrysler
529-433	6.5	62	1.5	<ul style="list-style-type: none"> • 3/8" deep Chrysler flange liquid inlet • 1/2" Chrysler flange evaporator inlet • 3/4" Chrysler flange evaporator outlet • 3/4" deep Chrysler flange outlet to compressor 	134a application, 3/8 female port w/plug, M8 hex bolt w/washer	04796464	Chrysler
529-436	6.5	62	1.5	<ul style="list-style-type: none"> • 3/8" deep Chrysler flange liquid inlet • 1/2" Chrysler flange evaporator inlet • 3/4" Chrysler flange evaporator outlet • 3/4" deep Chrysler flange outlet to compressor 	134a application, with bypass, LP Switch	05264744	97-99 Dodge/ Plymouth Neon

Block Valves

Part. No.	Superheat (Degrees)	MOP	Tonnage	Connections	Misc.	OE No.	OEM
529-444	6.5	62	1.5	<ul style="list-style-type: none"> • 3/8" deep Chrysler flange liquid inlet • 1/2" Chrysler pilot bushing evaporator inlet • 3/4" Chrysler pilot bushing evaporator outlet • 3/4" deep Chrysler flange outlet to compressor 	134a application	55036079AF	99-01 Dodge Ram 99-00 Plymouth Prowler
529-445	6.5	62	1.5	<ul style="list-style-type: none"> • 3/8" deep Chrysler flange liquid inlet • 1/2" Chrysler flange evaporator inlet • 3/4" Chrysler flange evaporator outlet • 3/4" deep Chrysler flange outlet to compressor 	134a application, LP Switch	05278510AE	00-01 Dodge/ Plymouth Neon
529-446	6.5	62	1.5	<ul style="list-style-type: none"> • 3/8" deep Chrysler flange liquid inlet • 1/2" Chrysler pilot bushing evaporator inlet • 3/4" Chrysler pilot bushing evaporator outlet • 3/4" deep Chrysler flange outlet to compressor 	134a application, LP Switch	05058079AA	Chrysler
529-448	6.5	62	1.5	<ul style="list-style-type: none"> • 3/8" deep Chrysler flange liquid inlet • 1/2" Chrysler pilot bushing evaporator inlet • 3/4" Chrysler pilot bushing evaporator outlet • 3/4" deep Chrysler flange outlet to compressor 	134a application, LP Switch	05290240AC	Chrysler
529-449	7	62	1.5	<ul style="list-style-type: none"> • 3/8" deep Chrysler flange liquid inlet • 1/2" Chrysler pilot bushing evaporator inlet • 3/4" Chrysler pilot bushing evaporator outlet • 3/4" deep Chrysler flange outlet to compressor 	134a application, Switch port	05179807AA	Chrysler
829-007	7	65	1.5	<ul style="list-style-type: none"> • 1/2" Metric Tube-O liquid inlet • 1/2" Tube-O evaporator inlet • 5/8" Tube-O evaporator outlet • 5/8 Metric Tube-O outlet to compressor 	134a application , with bypass	52458711	Delphi
829-013a	0	77	1.5	<ul style="list-style-type: none"> • 1/2" face seal o-ring liquid inlet • 1/2" threaded Tube-O evaporator inlet • 5/8" threaded Tube-O evaporator outlet • 5/8 face seal o-ring outlet to compressor 	134a application, cross charge, special cap with M8 bolt	XW4Z 19849 AA	Ford

Block Valves

Part. No.	Superheat (Degrees)	MOP	Tonnage	Connections	Misc.	OE No.	OEM
829-014	13.5	62	2.0	<ul style="list-style-type: none"> • 1/2" tube-o liquid inlet • 1/2" Chrysler pilot bushing evaporator inlet • 3/4" Chrysler pilot bushing evaporator outlet • 3/4" tube-o outlet to compressor 	134a application, stud	04734728	99-01 300M, Concorde, LHS, Intrepid
829-023	-2.5	72	2.5	<ul style="list-style-type: none"> • 3/8" slimline liquid inlet • 1/2" slimline evaporator inlet • 3/4" slimline evaporator outlet • 3/4" slimline outlet to compressor 	134a application, cross charge, stud	--	GM
829-025	-3	77	2.0	<ul style="list-style-type: none"> • 3/8" face seal o-ring liquid inlet • 1/2" threaded tube-o evaporator inlet • 5/8" threaded tube-o evaporator outlet • 5/8" face seal o-ring outlet to compressor 	134a application, cross charge, LP switch, cold control	YL1Z 19849 AA	Ford
829-040	9	51	1.5	<ul style="list-style-type: none"> • 1/2" tube-o liquid inlet • 1/2" Chrysler pilot bushing evaporator inlet • 3/4" Chrysler pilot bushing evaporator outlet • 3/4" tube-o outlet to compressor 	134a, cold control, stud	55056121AB / 55055773AI	Chrysler
829-043a	-6	72	1.5	<ul style="list-style-type: none"> • 3/8" face seal oring liquid inlet • 1/2" threaded tube-o evaporator inlet • 5/8" threaded tube-o evaporator outlet • 5/8" face seal o-ring outlet to compressor 	134a application, cold control, 2 studs	2GCH19849AC	Ford
829-053a	-6	77	2.0	<ul style="list-style-type: none"> • 3/8" face seal oring • 1/2" threaded tube-o evaporator inlet • 5/8" threaded tube-o evaporator outlet • 5/8" face seal o-ring outlet to compressor 	134a application, LP switch, cold control	2L1Z 19849 AB	Ford
829-060	-6	77	2.0	<ul style="list-style-type: none"> • 3/8" face seal oring liquid inlet • 1/2" threaded tube-o evaporator inlet • 5/8" threaded tube-o evaporator outlet • 5/8" face seal o-ring outlet to compressor 	134a application, LP switch, cold control	3L2Z 19849 CA	Ford
829-062a	-6	77	1.5	<ul style="list-style-type: none"> • 3/8" face seal oring liquid inlet • 1/2" threaded tube-o evaporator inlet • 5/8" threaded tube-o evaporator outlet • 5/8" face seal o-ring outlet to compressor 	134a application, LP switch, cold control	3L2H 19849 AA	Ford

Block Valves

Part. No.	Superheat (Degrees)	MOP	Tonnage	Connections	Misc.	OE No.	OEM
829-066	-6	77	2.0	<ul style="list-style-type: none"> • 3/8" face seal o-ring liquid inlet • 1/2" threaded tube-o evaporator inlet • 5/8" threaded tube-o evaporator outlet • 5/8" face seal o-ring outlet to compressor 	134a application, LP switch	4L1Z 19849 AB	Ford
829-069	8	69	1.25	<ul style="list-style-type: none"> • 1/2" tube-o liquid inlet • 1/2" tube-o evaporator inlet • 3/4" tube-o evaporator outlet • 3/4" tube-o outlet to compressor 	134a application, with bypass, stud	04798682	1996-2000 Chrysler Mini-van
829-071	7	68	1.75	<ul style="list-style-type: none"> • 1/2" tube-o liquid inlet • 1/2" tube-o evaporator inlet • 3/4" tube-o evaporator outlet • 3/4" tube-o outlet to compressor 	134a application, with bypass, stud	04734442AB	97-99 Caravan/ Voyager/ Town & Country
829-077a	0	77	1.75	<ul style="list-style-type: none"> • 1/2" axial seal liquid inlet • 1/2" tube-o evaporator inlet • 3/4" tube-o evaporator outlet • 3/4" axial seal outlet to compressor 	134a application, bypass, cold control, stud	05019218AE	01-04 Voyager/ Caravan
829-085a	0	77	1.75	<ul style="list-style-type: none"> • 1/2" axial seal liquid inlet • 1/2" tube-o evaporator inlet • 3/4" tube-o evaporator outlet • 3/4" axial seal outlet to compressor 	134a application, with bypass, stud	05061576AA	04-07 Chrysler Mini Van/ Pacifica
929-490	5.5	65	1.5	<ul style="list-style-type: none"> • 3/8" liquid inlet • 1/2" evaporator inlet • 5/8" evaporator outlet • 3/4" outlet to compressor 	134a application	--	Behr / Red Dot
929-491	6.5	62	1.25	<ul style="list-style-type: none"> • 3/8" liquid inlet • 1/2" evaporator inlet • 5/8" evaporator outlet • 3/4" outlet to compressor 	134a application, with stud	--	Valeo
929-492a	5.5	53.5	2.0	<ul style="list-style-type: none"> • 3/8" liquid inlet • 1/2" evaporator inlet • 5/8" evaporator outlet • 3/4" outlet to compressor 	134a application	--	--
929-493a	5.5	53.5	2.0	<ul style="list-style-type: none"> • 3/8" liquid inlet • 1/2" evaporator inlet • 5/8" evaporator outlet • 3/4" outlet to compressor 	134a application, with bypass	--	--

Block Valves

Part. No.	Superheat (Degrees)	MOP	Tonnage	Connections	Misc.	OE No.	OEM
929-494	8	53.5	2.0	<ul style="list-style-type: none"> • 3/8" liquid inlet • 1/2" evaporator inlet • 5/8" evaporator outlet • 3/4" outlet to compressor 	134a application	--	--
929-495	10	53.5	2.0	<ul style="list-style-type: none"> • 3/8" liquid inlet • 1/2" evaporator inlet • 5/8" evaporator outlet • 3/4" outlet to compressor 	134a application	--	Behr
929-496	8.5	53.5	2.0	<ul style="list-style-type: none"> • 3/8" liquid inlet • 1/2" evaporator inlet • 1/2" evaporator outlet • 5/8" outlet to compressor 	134a application	--	--
929-498a	8.5	53.5	1.5	<ul style="list-style-type: none"> • 3/8" liquid inlet • 1/2" evaporator inlet • 1/2" evaporator outlet • 5/8" outlet to compressor 	134a application	--	--
929-500	5.5	53.5	2.5	<ul style="list-style-type: none"> • 3/8" Ford o-ring liquid inlet • 1/2" Ford o-ring evaporator inlet • 5/8" Ford o-ring evaporator outlet • 5/8" outlet to compressor 	134a application, 3/8" port with plug	93DA 19849 AA	Ford
929-503	5	53.5	2.0	<ul style="list-style-type: none"> • 3/8" liquid inlet • 1/2" evaporator inlet • 1/2" evaporator outlet • 5/8" outlet to compressor 	134a, dual switch ports, stud	540254	International Truck
929-506a	8.5	53.5	1.5	<ul style="list-style-type: none"> • 3/8" liquid inlet • 1/2" evaporator inlet • 1/2" evaporator outlet • 5/8" outlet to compressor 	134a application, bypass, M10 switch port, stud	--	--
929-507	8	53.5	1.5	<ul style="list-style-type: none"> • 3/8" liquid inlet • 1/2" evaporator inlet • 1/2" evaporator outlet • 5/8" outlet to compressor 	134a application, switch port, stud	540255	International Truck
929-508	5.5	53.5	2.5	<ul style="list-style-type: none"> • 3/8" liquid inlet • 1/2" evaporator inlet • 1/2" evaporator outlet • 5/8" outlet to compressor 	134a application, 3/8 female port, 7/16 male port	90DA 19849 AA	Ford Misc Components



Parker Futura™ Air Conditioning Hose

Parker Futura™ is a highly flexible air conditioning hose ideal for the tight route fittings found in mobile systems. The five-layer design provides for excellent sealing, superior burst and tensile strength and lower permeation.

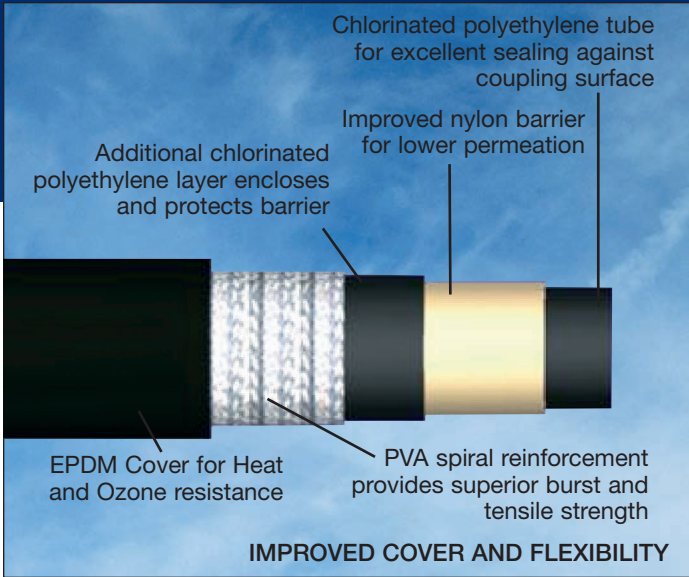

Applications:

Air conditioning hose for mobile R-12 and R-134a systems

Specifications:

Meets or exceeds all SAE J2064 performance requirements

Temperature Range:

-30 To 125°C

Couplings:

Field crimp

Available in:

- King Packs (Pallets)
- Large Reels (#6-5/16 = 600')
- (#8-13/32 = 600')
- (#10-1/2 = 500')
- (#12-5/8 = 400')
- 250 ft. Reels
- 50 ft. Coils
- 25 ft. Coils

Futura™

Nom I.D. (in.)	Part No.	I.D.		O.D.		Bend Radius		Weight	
		mm	(in.)	mm	(in.)	mm	(in.)	g/m	(lb/ft)
5/16	BHK006	7.87	(.310)	19.1	(.750)	6.2	(3.0)	2.98	(.20)
13/32	BHK008	10.6	(.418)	23.0	(.906)	88.9	(3.5)	4.17	(.28)
1/2	BHK010	12.78	(.503)	5.4	(1.00)	101.6	(4.0)	4.70	(.32)
5/8	BHK012	16.2	(.637)	8.6	(1.125)	114.3	(4.5)	5.51	(.37)



Guardian Barrier™ Air Conditioning Hose

Parker Guardian Barrier™ Hose utilizes triple layer technology, exceeds current industry standards for permeation and is recognized worldwide for excellence in air conditioning systems.

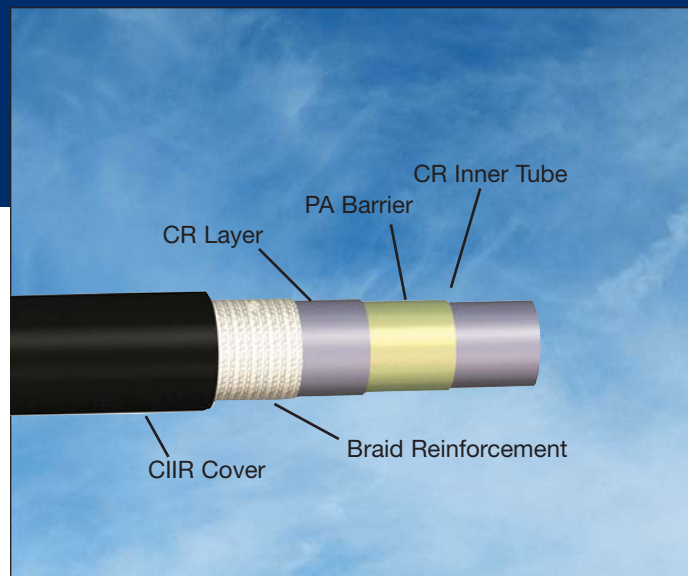

Features:

- RP = new reduced permeation (see chart on reverse)
- Mechanical coupling attachment; no chemical sealing
- Noise dampening capabilities
- Improved resistance to vibration transmissibility
- Excellent moisture ingress properties
- Kink resistance and excellent flexibility
- Fluids: R134a/PAG oil
- Coupling: Available in aluminum or steel with multiple bend custom end connections



P-90 Barb Detail

7637

Nom I.D. (in.)	Part No.	I.D. mm (in.)	O.D. mm (in.)	Bend Radius mm (in.)	Weight g/m (lb/ft)	Continuous [(Intermittent)] Temp Service C° (F°)
5/16	763731	8.23 (.324)	14.73 (.580)	58.9 (2.32)	155 (.104)	-40(-40) to 125 (257)
13/32	763741	10.67 (.420)	17.27 (.680)	69.1 (2.72)	187 (.127)	[-40(-40) to 135 (275)]
1/2	763750	12.95 (.510)	19.43 (.765)	76.20 (3.00)	206 (.138)	
5/8	763763	16.13 (.635)	23.62 (.930)	94.5 (3.72)	296 (.199)	
3/4	763775	19.43 (.765)	27.43 (1.080)	109.7 (4.32)	403 (.271)	

7639

Nom I.D. (in.)	Part No.	I.D. mm (in.)	O.D. mm (in.)	Bend Radius mm (in.)	Weight g/m (lb/ft)	Continuous [(Intermittent)] Temp Service C° (F°)
5/16	763931	8.23 (.324)	15.75 (.620)	63.5 (2.50)	186 (.125)	-40(-40) to 125 (257)
13/32	763941	10.67 (.420)	18.80 (.740)	76.2 (3.00)	244 (.164)	[-40(-40) to 135 (275)]
5/8	763963	16.13 (.635)	24.38 (.960)	96.5 (3.80)	333 (.224)	
3/4	763975	19.43 (.765)	28.45 (1.120)	114.3 (4.50)	460 (.309)	

Misc Components

Part No.	Description
085108-00	Low pressure switch
080765-00	High Pressure Relief Valve 134a w/oring
080660-00	Female Quick Disconnect Fitting
080972-00	Ford pressure switch YC2H 19E561 AA (17-19 PSIG)
085873-00	Ford pressure switch 95BW 19E561 AA (21-23 PSIG)

Principal Terms and Conditions Of Sale

1. Terms And Conditions Of Sale. This order shall be subject to and is expressly conditioned upon Buyer's assent to the terms and conditions set forth herein, notwithstanding any terms and conditions that may be contained in any order, acknowledgment or other form of Buyer. Such terms and conditions of Buyer shall not bind Seller unless accepted by it in writing, whether or not they materially alter this order.

2. Prices; Quotes. Until orders are accepted, all prices are subject to change without notice. All quotations expire sixty (60) calendar days from the date of quotation, unless withdrawn sooner or otherwise stipulated by Seller in writing.

3. Delivery. Unless otherwise specified by Seller in writing, all shipments are F.O.B. Factory. Title to and risk of loss of the products transfers to Buyer upon delivery to the carrier. Seller shall not be liable for any delays in or failure of delivery due to acts of God or public authority, labor disturbances, accidents, fires, floods, extreme weather conditions, failure of and delays by carriers, shortages of material, delays of a supplier or any other cause beyond Seller's control. In no event shall Seller be liable for incidental,

consequential or special damages arising out of a delay in or a failure of delivery. Buyer's requested delivery date or schedule shall be approximate and subject to Seller's acceptance.

4. Payment Terms. Unless otherwise specified by Seller in writing, terms of payment for the products are as follows: 2% 10, 25 NET 30. Invoices dated the first (1st) to fifteenth (15th) of month shall be paid by twenty-fifth (25th) of same month; Invoices dated sixteenth (16th) to end of month shall be paid by the tenth (10th) day of the following month. If at any time Seller shall become dissatisfied with Buyer's credit, Seller shall have the right to decline to make further shipments hereunder unless Buyer pays cash in advance or until such time as Buyer's credit shall be reestablished to Seller's satisfaction; provided, however, that such refusal to ship shall not render Seller liable for nonperformance under this contract, in whole or in part.

5. Taxes. Seller prices do not include any applicable sales, use, excise or similar taxes. If, under law or government regulation, Seller is required to pay or collect any tax upon the products arising from the sale, delivery, transportation, use or consumption of said products by Buyer, whether directly or indirectly, the price to be paid by Buyer hereunder shall be increased by the amount of any such tax. Buyer agrees to pay such tax as part of the purchase price. If such tax is not collected at the time of payment of sales price, Buyer will hold Seller harmless therefor.

6. Minimum Order. Unless otherwise specified in writing by Seller, there is a minimum order of (a) one hundred dollars (\$100) on items sold to wholesalers and contractors; and (b) two hundred fifty dollars (\$250) on items sold to original equipment manufacturers.

7. Claims. Payment on account shall not prejudice claims on account of omissions or shortages in shipment, but no such claim will be allowed unless made within ten (10) working days after receipt of the products by Buyer.

8. Quantity. In the making of products to customer's specification, it is impossible to produce exactly the quantity ordered and it is therefore agreed that all orders are subject to over or under shipment of five percent (5%) on orders over five hundred dollars (\$500) and ten percent (10%) on orders less than five hundred dollars (\$500).

9. Warranty. Seller warrants the goods to be sold hereunder to be free from defects in material and workmanship. This warranty shall terminate in all instances unless Buyer claims for breach thereof in writing within ninety (90) days from delivery pursuant to Section 3 and claims not made within such period are waived. If the goods have been used, the warranty applies only if the goods fail to function properly because of such defect in material or workmanship under normally recom-

mended operating conditions within design limitations.

The warranty extends only to goods owned by the original purchaser and applies only to parts manufactured by Seller. Parts incorporated in the Seller's products, but not of Seller's own manufacture, will carry only the warranty of their manufacture. Seller will endeavor to secure for a Buyer the benefits of such warranty, if inspection proves such parts to be defective.

The warranty does not apply to goods that have been damaged after shipment to Buyer where the damage is not due to a defect in material or workmanship of the goods, nor does it apply to goods that have been altered or repaired by anyone other than the Seller's authorized employees, nor to goods furnished by Buyer or acquired at Buyer's request and/or Buyer's specifications.

When goods are alleged to be defective, Seller may, at his option, inspect the same at their site, or request that the goods be returned to Seller with Transportation charges prepaid by Buyer. THE ABOVE WARRANTY COMPRISES SELLER'S SOLE AND ENTIRE WARRANTY OBLIGATIONS AND LIABILITY TO BUYER, ITS CUSTOMER AND ASSIGNS IN CONNECTION WITH THE GOODS SOLD HEREUNDER. ALL OTHER WARRANTIES, EXPRESS OR IMPLIED, INCLUDING BUT NOT LIMITED TO, WARRANTIES OF MERCHANTABILITY AND FITNESS FOR A PARTICULAR PURPOSE, ARE EXPRESSLY EXCLUDED.

10. Limitation Of Liability. IF SELLER DETERMINES THAT THE GOODS ARE NOT AS WARRANTED, SELLER'S SOLE OBLIGATION, WHETHER ARISING IN CONTRACT OR TORT, SHALL BE TO REPAIR OR REPLACE, AT ITS OPTION, THE GOODS WITHOUT CHARGE TO BUYER. IN NO EVENT SHALL SELLER BE LIABLE FOR INCIDENTAL, CONSEQUENTIAL OR SPECIAL DAMAGES ARISING OUT OF A DELAY IN OR FAILURE OF DELIVERY, DEFECTS IN MATERIAL OR WORKMANSHIP, OR ARISING OUT OF A BREACH BY SELLER OF ANY OTHER TERM OR OBLIGATION OF SELLER UNDER THIS CONTRACT.

11. Changes In Specification Or Design. If Buyer requests changes in specifications or design relating to any goods, delivery schedules shall be revised, if necessary, and an equitable adjustment, upward or downward, shall be made in price.

12. Cancellation And Reschedules. Cancellation and reschedules are subject to acceptance by Seller, and are also subject to cancellation charges and price increases.

13. Returned Goods. No goods shall be returned without Seller's consent. Freight must be prepaid by Buyer on all returned goods shipments. Goods returned with Seller's consent are subject to the following restocking charge:

During 1st year - 15% During 2nd year - 30%

During 3rd year - 50% After 3 years - 100%

The determining date for the purposes of calculating the restocking charge is the earlier of the date stamped on the product or the shipping date. The cost of any additional charges for repacking, repainting, etc. will also be deducted from Buyer's return credit.

14. Special Tools. Any special tools, jigs, dies, patterns, etc., which Seller makes or acquires for Buyer, notwithstanding any charge therefor, shall be and remain Seller's property subject to its possession and control; provided, however, that at time of quotation special arrangements may be made for retention of title by Buyer upon payment of the full cost thereof. In no event shall Buyer have any interest in any tooling belonging to Seller which is utilized in the production of goods for Buyer, or which has

been converted or adapted by Seller for such use, notwithstanding any charge of any such utilization, conversion or adaptation. Seller shall have the right to alter, discard or otherwise dispose of any tooling without liability to Buyer when for two (2) consecutive years no orders have been received from Buyer requiring the use of such tooling. 15. Buyer's Property. Any designs, tools, patterns, materials, drawings, information or equipment furnished by Buyer, or any special tools made or acquired for the Buyer by the Seller which become Buyer's

property, shall be used only in the production of goods ordered by Buyer and not otherwise, unless by Buyer's written consent; provided that such property may be considered obsolete and destroyed by Seller when for two (2) consecutive years no orders are received from Buyer for products to be made with such property. Seller agrees to exercise reasonable care with respect to property and equipment while in its possession and control, but shall not be responsible for loss or damage occurring without its fault or negligence or for ordinary wear and tear.

16. Patent Indemnity. Seller shall have no liability for patent infringement unless the goods furnished hereunder in and of themselves constitute the infringement. If they do, and Seller is notified of the claim of infringement within ten (10) days after such claim is received by the Buyer and is permitted to settle or defend such claim, Seller will indemnify the buyer against the reasonable expense of defending suit and against any judgment or settlement to which Seller agrees. However, such indemnity will be limited to an amount not exceeding the price paid by Seller for the infringing goods. If an injunction is issued against the further use of the goods, Seller will have the option of either procuring for the Buyer the right to use the goods, replacing them with noninfringing goods, modifying them so that they become non-infringing, or refunding the purchase price. The foregoing constitutes Seller's entire warranty and liability as to patents. If the goods furnished hereunder are in accordance with a design furnished by the Buyer, the Buyer will defend and save harmless Seller from all costs, expenses, and judgments on account of any claim of infringement of any patent.

17. Government Contracts. If Buyer notifies Seller that goods hereunder are for use under a prime contract with an agency of the United States Government, the following terms and conditions of the Armed Services Procurement Regulations shall be incorporated into Seller's terms of sale insofar as Buyer may be required to incorporate such provisions in its subcontracts or insofar as applicable to the goods sold hereunder: WALSH-HEALEY PUBLIC CONTRACTS ACT (12-605); RENEGOTIATION (7-103.13); BUY AMERICAN ACT (6-104.5); EXAMINATION OF RECORDS (7-104.15); AUDIT AND RECORDS (7-104.41); PRICE REDUCTION FOR DEFECTIVE COST OR PRICING DATA (7-

104.29); CONVICT LABOR (12-203); NOTICE TO THE GOVERNMENT OF LABOR DISPUTES (7-104.4); WORK HOURS ACT (12-303.1); EXCESS PROFITS (7-104.11); MILITARY SECURITY REQUIREMENT (7-104.12); TERMINATION (8-706); EQUAL OPPORTUNITY EMPLOYER (12-802).

18. Compliance With Law. Seller warrants that products sold or services furnished will be provided or furnished in full and complete compliance with all applicable federal state or local statutes, rules, regulations and orders, including those pertaining to labor, hours and conditions of employment, and, in particular, the Fair Labor Standards Act, as amended, and Executive Order No. 11246 (Equal Employment Opportunity) effective October 24, 1965, with all amendments thereto or as it may be superseded. Seller agrees that all the provisions of said Executive Order, as it may be amended or superseded, are hereby made a part hereof by reference and are binding upon Seller. Seller further agrees and confirms that Seller, as a subcontractor or vendor, has complied with and will comply with the provisions of said Executive Order and the rules and regulations promulgated under the authority thereof, including, among others, reporting requirements.

19. Safe Operation. People doing any work on a refrigeration system must be qualified and completely familiar with the system and Refrigeration Components Group products involved, or all other precautions will be meaningless. Such qualification includes reading and understanding pertinent Refrigeration Components Group product bulletins prior to installation or servicing work. Buyer agrees to provide adequate warnings and information to its employees and other users of the goods purchased hereunder in order to safeguard against improper installation or service procedures.

20. Nuclear Sales. If the Buyer or ultimate user of the goods sold hereunder intends to use such goods in any nuclear installation or activity, Buyer shall so notify Seller and subsequently negotiated Nuclear Terms of Sale shall become a part of and control the contract.

21. Miscellaneous. Stenographical and clerical errors are subject to correction. This contract may not be modified or rescinded nor any of its provisions waived unless such modification, rescission or waiver is in writing, specifically states that it is an amendment, rescission or waiver of this contract and is signed by both parties hereto. This contract is intended by the parties as a final expression of their agreement and a completed and exclusive statement of the terms thereof. This contract shall be governed and construed under the laws of the State of Ohio.



WARNING!

FAILURE OR IMPROPER SELECTION OR IMPROPER USE OF THE PRODUCTS AND/OR SYSTEMS DESCRIBED HEREIN OR RELATED ITEMS CAN CAUSE DEATH, PERSONAL INJURY AND PROPERTY DAMAGE.

This document and other information from Parker Hannifin Corporation, its subsidiaries and authorized distributors provide products and/or system options for further investigation by users having technical expertise. It is important that you analyze all aspects of your application and review the information concerning the product or system in the current product catalog. Due to the variety of operating conditions and application for these products or systems, the user, through its own analysis and testing, is solely responsible for making the final selection of the products and systems and assuring that all performance, safety and warning requirements of the application are met. The products described herein, including without limitation, product features, specifications, designs, availability and pricing, are subject to change by Parker Hannifin Corporation and its subsidiaries at any time without notice.

OFFER OF SALE

The items described in this document are hereby offered for sale by Parker Hannifin Corporation, its subsidiaries or its authorized distributors. This offer and its acceptance are governed by the provisions stated on the separate page of this document entitled "Offer of Sale."

How to Place An Order

To order dryers, accumulators and txvs contact:

Mobile Climate Systems
100 Dunn Road
Lyons, NY 14489-9763
Phone: 315.946.4891
Fax: 315.946.3391

To order hose contact:

Mobile Climate Systems
Kennett plant
1200 Ely St., North-by-pass
Kennett, MO 63857
Phone: 573.717.4691
Fax: 573.888.0214

Not sure who to call?

Mobile Climate Systems:
100 Dunn Road
Lyons, NY 14489-9763
Phone: 315.946.4891
Fax: 315.946.3391